

HD/4Kインテグレートドカメラ
インターフェース仕様書

AW-UE160
2023/12/1

パナソニック コネクト株式会社

■目次

1. はじめに	…3
2. 概要	…4
3. コマンドタイプ	…5
4. 通信方式	…6
5. 更新通知	…9
6. 特殊シーケンス	…13
7. エラー返信	…19
8. メニュー対応表	…21
9. コマンド仕様一覧	…34

1.はじめに

本書は、カメラをIP通信またはシリアル通信で操作する際の外部インターフェース仕様書です。

2.概要

本書の概要は以下となります。

①外部インターフェース概要

パン、チルトやホワイトバランス調整等の制御を行うことができます。
また、ゲイン等のカメラ情報を問合せにより取得できます。
カメラとは、TCPの上位プロトコルであるHTTPで各種機能进行操作します。
詳細は、3～4章を参照してください。

②カメラ情報の更新通知

別の端末で変更したゲイン等の値が、自端末に通知されてカメラ情報を取得することができます。
1台のカメラを複数の端末で制御しているときに有用で、更新通知を受信できるように設定しておく、他の端末で変更された情報を取得することができます。
詳細は、5章を参照してください。

③カメラ情報一括取得

カメラ情報を一括で取得することができます。1つずつカメラ情報を問い合わせる必要がないため、起動時など一度にカメラ情報が必要な場合に有用です。
詳細は、6章を参照してください。

④エラー返信

上記①のコマンドによりエラーが発生した場合やAWBの結果がエラーであった場合に、ER1～ER3のエラーを返信します。
詳細は、7章を参照してください。

⑤メニュー一覧とコマンド対応表

AW-UE160のメニュー一覧と各メニュー項目に関連するコマンドをまとめた表です
詳細は、8章を参照してください。

⑥制御・問合せコマンド

AW-UE160で採用されているコマンドの仕様を記載しています。
詳細は、9章を参照してください。

3.コマンドタイプ

外部インターフェースコマンドには、回転台コマンドとカメラコマンドという2種類のフォーマットのコマンドが存在します。

3-1.回転台コマンド

Pan/Tiltなどの主に回転台部を制御するインターフェースです。

#(0x23)で始まり、[CR](0x0d)で終了します。

例)Pan停止コマンド

```
# P 5 0 [CR]
```

```
0x23 0x50 0x35 0x30 0x0D
```

※IP通信の場合は[CR]は不要です

9章:コマンド仕様一覧のCommand Typeがptzとなっているコマンドが回転台コマンドです

3-2.カメラコマンド

カメラのレンズ制御や映像調整などに関するインターフェースです。

[STX](0x02)で始まり、[ETX](0x03)で終了します。カメラコマンドの場合は[Data]の前に":"が必要です。

例)Auto Focus設定

```
[STX] O A F : 1 [ETX]
```

```
0x02 0x4F 0x41 0x46 0x3A 0x31 0x03
```

※IP通信の場合は[STX][ETX]は不要です

4.通信方式

シリアル通信、IP通信それぞれでカメラを制御することが可能です。

4-1.シリアル通信

RS422で通信を行います。通信仕様は下記のとおりです。

Method	Half Duplex
Communication Speed	9600bps, 38400bps, 115200bps
Data bit	8bit
Stop bit	1bit
Parity	None
Flow control	None

▼シリアル通信シーケンス

回転台コマンドの場合

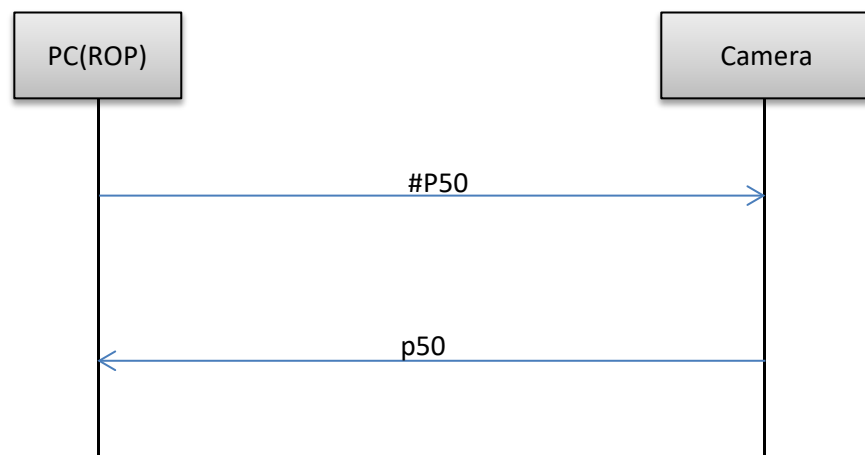

カメラコマンドの場合

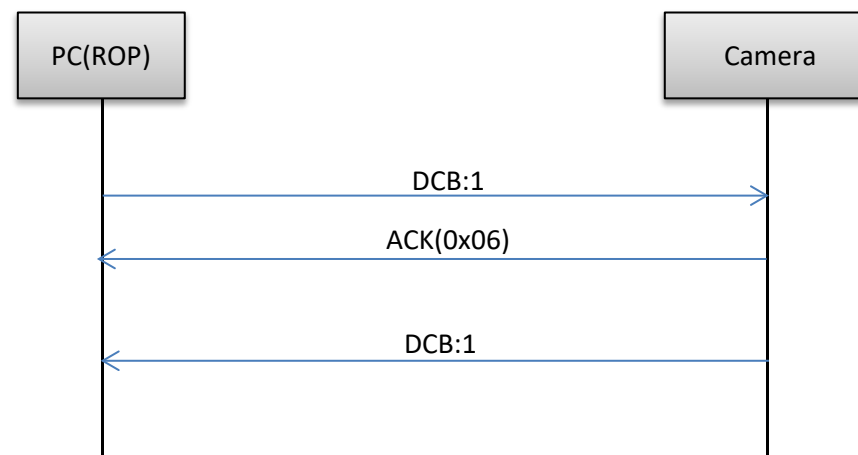

【制限事項】

1. 制御コマンドを使用する場合、コマンドとコマンドの送信間隔は、16ms空けて送信してください。
2. 他設定などの条件によっては、効果が反映されない設定（※排他制御条件は8章:メニュー対応表を参照してください）があります。
3. 設定を変更するコマンドは、変更が必要なタイミングで送信してください（定期的に送信しないでください）。

4-2.IP通信

回転台コマンドの場合

▼送信フォーマット

http://[IP Address]/cgi-bin/aw_ptz?cmd=[コマンド]&res=[Type]

※IP Address・・・接続先カメラのIPアドレス

※コマンド・・・ 9章:コマンド仕様一覧の表の「コマンド」欄の内容

※Type・・・・・・「1」固定

▼受信フォーマット

200 OK “コマンド”

※コマンド・・・各コマンドの応答値。

HTTPメッセージボディに設定されます。

送信したコマンドに対するエラーの通信シーケンスは

7章:エラー通信を参照してください

▼IP通信シーケンス

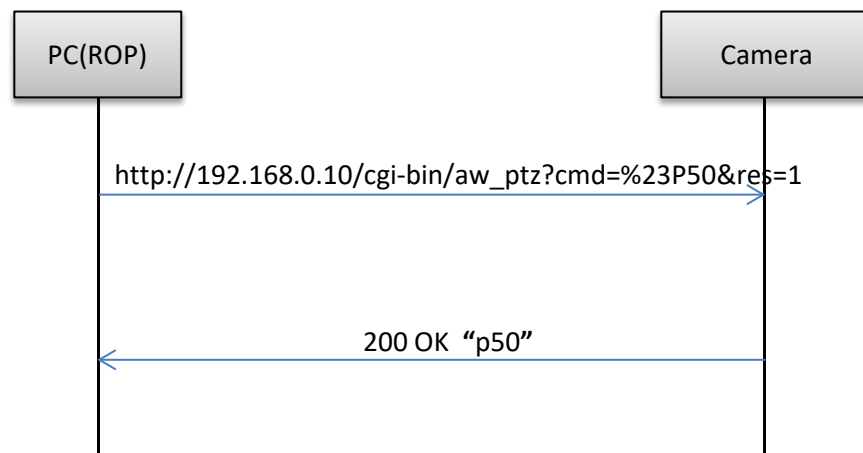

※使用するブラウザやミドルウェアによっては、「#」はASCII変換で「%23」と変換しなければならない場合があります。

カメラコマンドの場合

▼送信フォーマット

http://[IP Address]/cgi-bin/aw_cam?cmd=[コマンド]&res=[Type]

※IP Address・・・接続先カメラのIPアドレス

※コマンド・・・ 9章:コマンド仕様一覧の表の「コマンド」欄の内容

※Type・・・・・・「1」固定

▼受信フォーマット

200 OK “コマンド”

※コマンド・・・各コマンドの応答値。

HTTPメッセージボディに設定されます。

送信したコマンドに対するエラーの通信シーケンスは

7章:エラー通信を参照してください

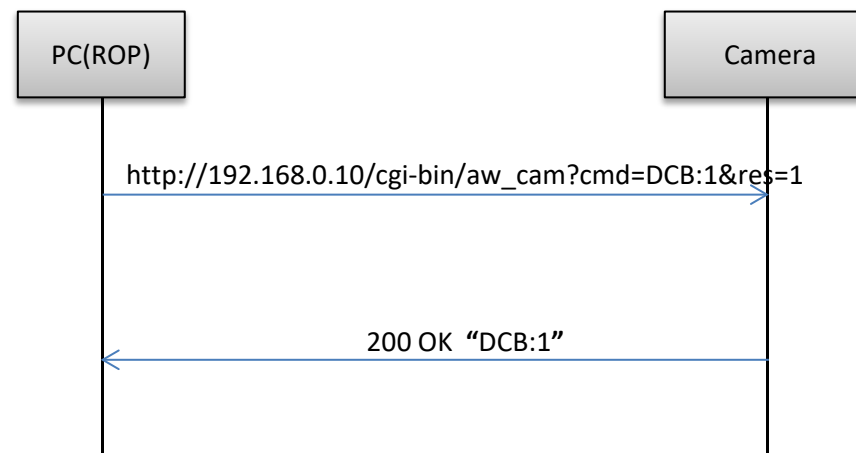

【制限事項】

1. 制御コマンドを使用する場合、コマンドとコマンドの送信間隔は、16ms空けて送信してください。
2. HTTPのコネクションでKeep-Aliveを設定することができません。
1コマンドの送信または受信単位で接続と切断を行います。
3. 他設定などの条件によっては、効果が反映されない設定（※排他制御条件は8章:メニュー対応表を参照してください）があります。
4. 設定を変更するコマンドは、変更が必要なタイミングで送信してください（定期的に送信しないでください）。

5.更新通知

前章までで述べた外部インターフェースコマンドの制御・応答の仕様では

- A) ある端末によってカメラ設定が変更されても、他の端末は、カメラへ問合せコマンドを送信しない限り、その設定変更を知ることができない
- B) プリセット再生・AWB/ABB実行など、処理時間がかかる制御コマンドの場合、その処理が完了するまで応答を待たなければならないという制約があります。

そこで、カメラから端末へ、自発的に情報を送信することにより、

- A) ある端末によってカメラ設定が変更されると、他の端末にも即座にその設定変更を通知する
- B) 処理時間がかかる制御コマンドは、コマンドを受け付けた時点でHTTP応答を返し、処理が完了した時点で、処理結果を別途通知することができます。

これを、カメラ情報の更新通知機能といいます。

以降、この機能を「更新通知」と呼びます。

5-1.更新通知のシーケンス

カメラの設定や状態が変更になると更新通知を送信します。

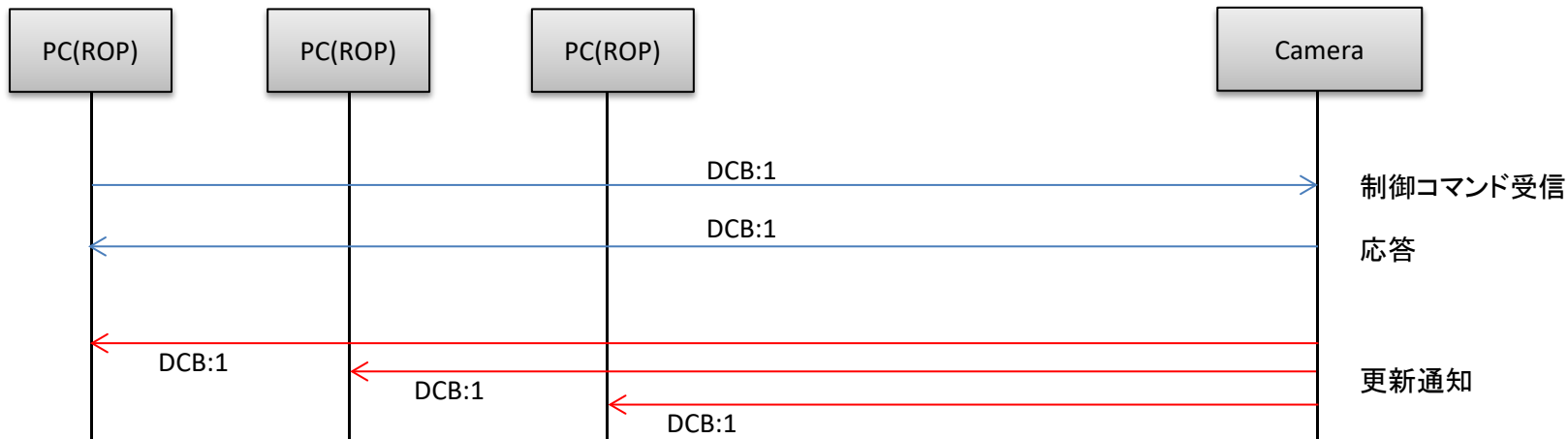

※更新通知が出ないコマンドもあります。9章:コマンド仕様一覧を参照してください

※コマンド制御により複数のコマンドのパラメータが変わった場合、変更があったすべてのコマンドの更新通知を送信します。

5-2.更新通知のデータフォーマット

▼シリアル

回転台コマンドの場合、[CR](0x0d)で終了します

カメラコマンドの場合、[STX](0x02)で始まり、[ETX](0x03)で終了します。

▼IP

更新通知は、TCPプロトコル通信により、更新通知開始コマンドで指定した端末側TCPポート番号へ通知されます。

受信したデータの内訳は以下です。

【受信データ】

Reserve (22Byte)	サイズ (2Byte)	Reserve (4Byte)	更新通知情報 (可変長:最大504Byte)	Reserve (24Byte)
---------------------	-----------------------	--------------------	----------------------------------	---------------------

受信データフォーマットの「更新通知情報」に更新された情報が設定されています。

また、カメラから受信するデータは可変長です。

更新通知情報のサイズは、「サイズ」エリアの設定値から8Byteを引いた値が「更新通知情報」のサイズになります。

・「更新通知情報」のデータ長 = 「サイズ」 - 8Byte

【更新通知情報フォーマット】

[CR][LF][各コマンドの応答コマンド形式][CR][LF]

※ [CR]:0x0d、[LF]:0x0aです。

例1)Power: On

[CR][LF]p1[CR][LF]

例2)カラーバー: On

[CR][LF]DCB:1[CR][LF]

5-3.更新通知の受信開始/終了の手続き

IPで更新通知を受ける際は事前に更新通知受信開始処理を行う必要があります。
その際、更新通知を受信する(送信してもらう)ための端末側TCPポート番号を指定します。

① 更新通知受信開始手順

例)カメラのIPアドレスが「192.168.0.10」で、受信を開始したい場合

`http://192.168.0.10/cgi-bin/event?connect=start&my_port=31004&uid=0`

※ my_port … 端末側TCPポート番号(任意の空ポート)

【更新通知受信開始シーケンス】

更新通知を受信したい端末から、更新通知受信開始コマンドを送信します。

コマンドを受信したカメラからは、「204 No Content」が返信されます。



【注意】

LANケーブル抜けなどによる通信が切断された場合は、更新通知受信開始手順を行ってください。

② 更新通知受信終了手順

クライアントのアプリケーションを終了する場合は、更新通知受信終了手順を必ず行ってください。

例)カメラのIPアドレスが「192.168.0.10」で、受信を終了したい場合

`http://192.168.0.10/cgi-bin/event?connect=stop&my_port=31004&uid=0`

※ my_port … 端末側TCPポート番号

【更新通知受信終了シーケンス】

更新通知を受信している端末から、更新通知受信終了コマンドを送信します。
コマンドを受信したカメラからは、「204 No Content」が返信されます。

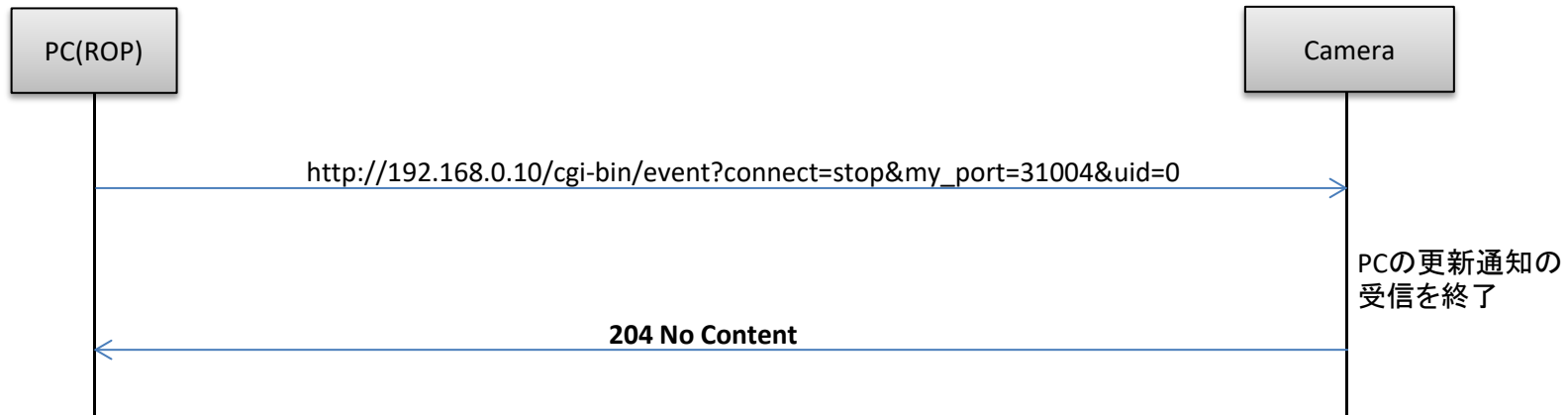

③ 更新通知登録台数

カメラと接続されている外部機器 (RPリモコン他) の台数を下記コマンドで問い合わせることができます。
接続数は更新通知の受信開始手続きで増加し、受信終了手続きまたは送信相手と通信ができない時に減少します。
カメラから更新通知を同時に受信できる端末数は5台です。RPリモコンが接続されている場合も1台にカウントされます。
例) カメラのIPアドレスが「192.168.0.10」で、登録台数を問合せたい場合
`http://192.168.0.10/cgi-bin/man_session?command=get`

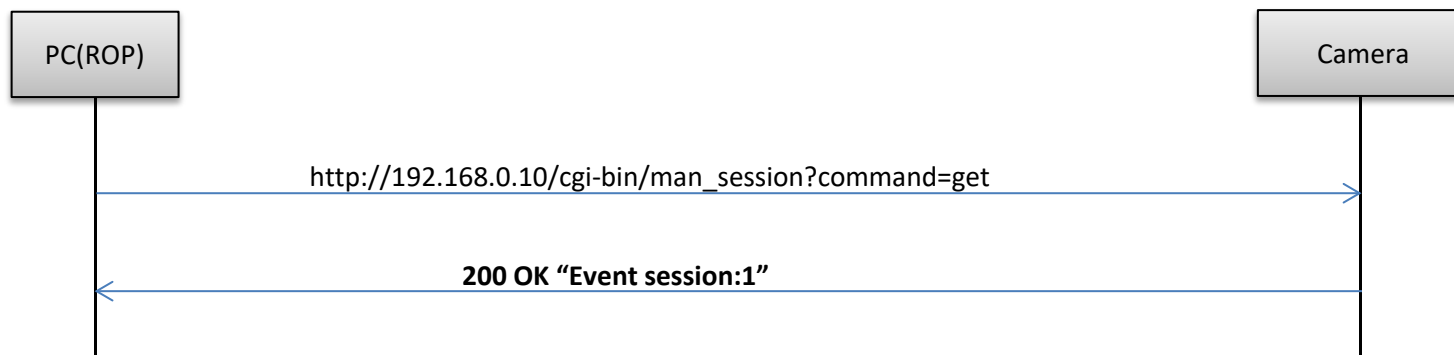

6. 特殊シーケンス

カメラの設定や状態が変更される以外に、更新通知が送信される場合があります。以下にそのケースを示します。
なお、シーケンス中のすべての端末は、更新通知開始コマンドを送信済みであり、カメラからの更新通知を受信できる状態にあるものとします。

6-1. バージョン情報通知

バージョン情報を60秒周期で通知します。
通知内容は9章のQSVの項目を参照してください。

【バージョン情報通知のシーケンス】

カメラがバージョン情報を60秒周期で送信し、端末PC1とPC2はバージョン情報を受信します。

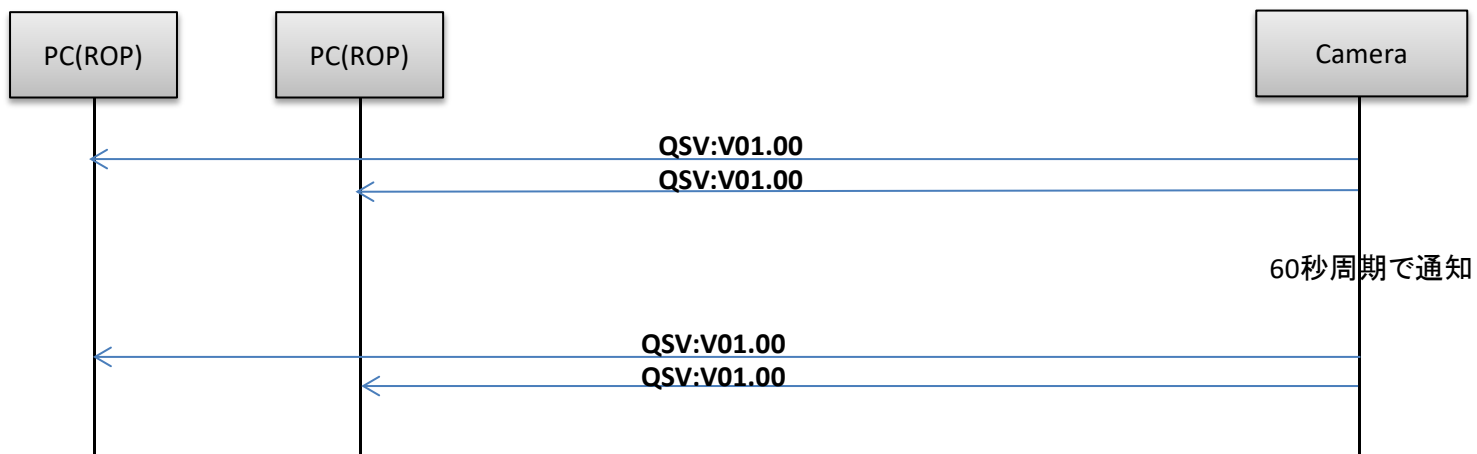

6-2.エラー情報

カメラがエラー情報を検知した場合、30秒周期でエラー情報を通知します。
エラーが復旧した場合、1回のみ[Error Code 00:Normal]を通知します。
エラーを検知していない場合は、通知されません。
通知内容は9章の#RERを参照してください

【エラー情報通知のシーケンス】

カメラがエラーを検知すると、エラー情報を各端末に送信し、端末PC1とPC2はエラー情報を受信します。

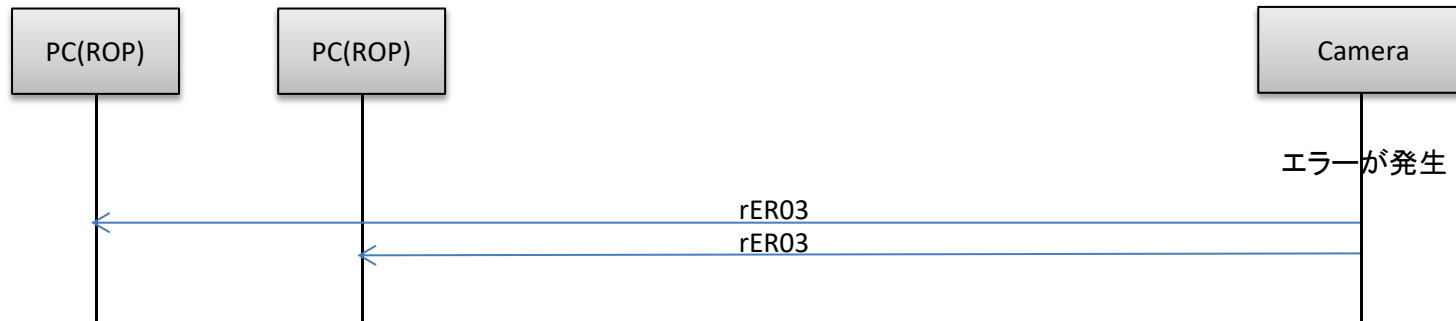

6-3. レンズ情報通知

レンズ情報通知を「On: 通知する」に設定した場合、LPI情報(レンズ情報)に変更があった場合に300ミリ秒周期で通知します。

通知コマンド	詳細
LPI[ZZZ][FFF][III]	ZZZ ズーム位置 FFF フォーカス位置 III アイリス位置 (それぞれ3桁で表現)

【レンズ情報通知のシーケンス】

レンズ情報Onコマンド(#LPC1)を受信すると、レンズ情報通知を開始します。

カメラがレンズ情報の変更を検知すると、変更されたレンズ情報を各端末に送信し、端末PC1とPC2はLPI(レンズ)情報を受信します。

レンズ情報Offコマンド(#LPC0)を受信すると、レンズ情報通知を停止します。

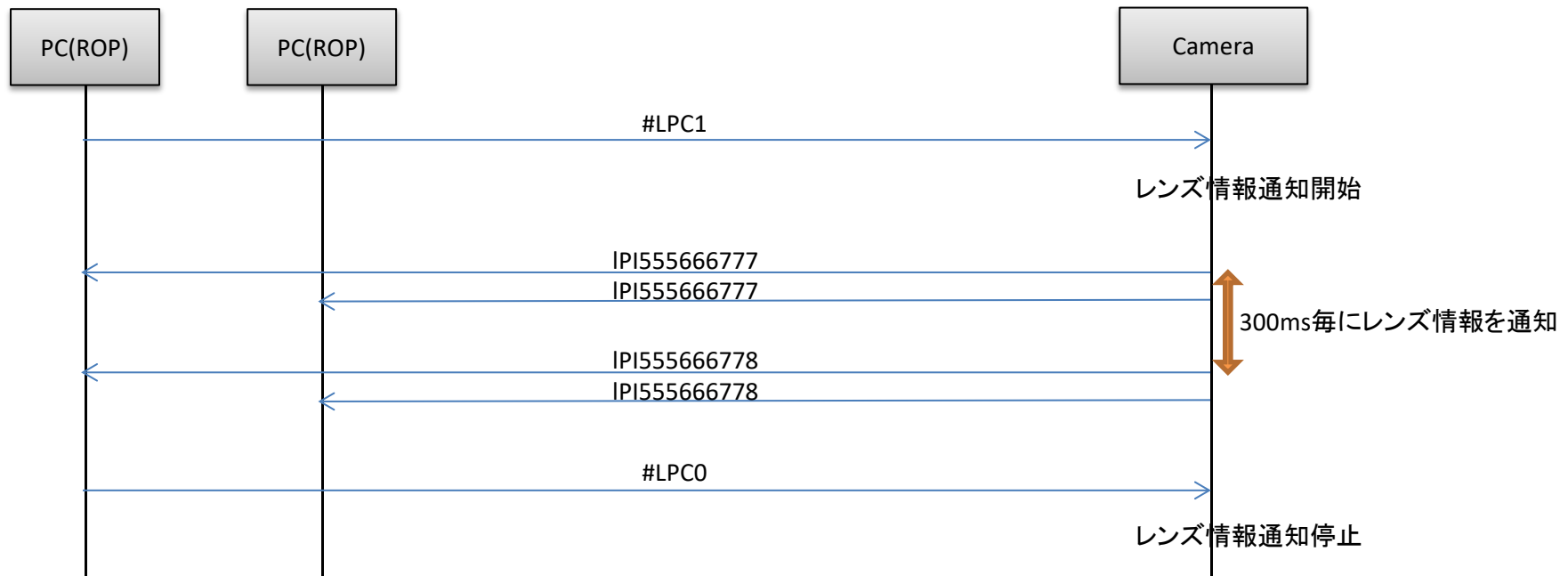

6-4.Preset再生

カメラでのプリセット再生が完了すると、プリセット再生完了通知を更新通知として送信します。

通知コマンド	詳細
q[Data]	再生されたPreset番号-1

【プリセット再生のシーケンス】

プリセット番号08を再生するシーケンスです。

プリセット再生コマンドを受け付けた時点で、「s07」が応答として返信され、その後再生が完了した時点で、別途「q07」が更新通知として通知されます。

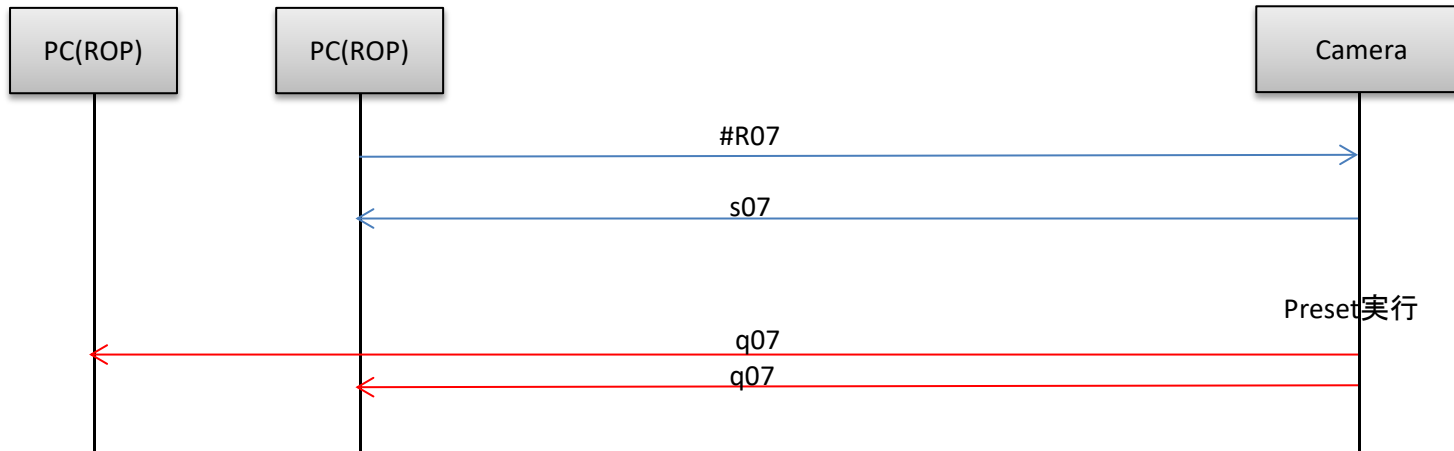

6-5.AWB/ABB実行

カメラでのAWB/ABBが完了すると、実行結果を更新通知として送信します。

通知コマンド	詳細
OWS	AWB成功
OAS	ABB成功

【AWB/ABB実行時のシーケンス】

AWB/ABB実行コマンドを受け付けた時点で応答を返信し、その後実行が完了した時点で、別途OWS/OASが更新通知として通知されます。

シリアル

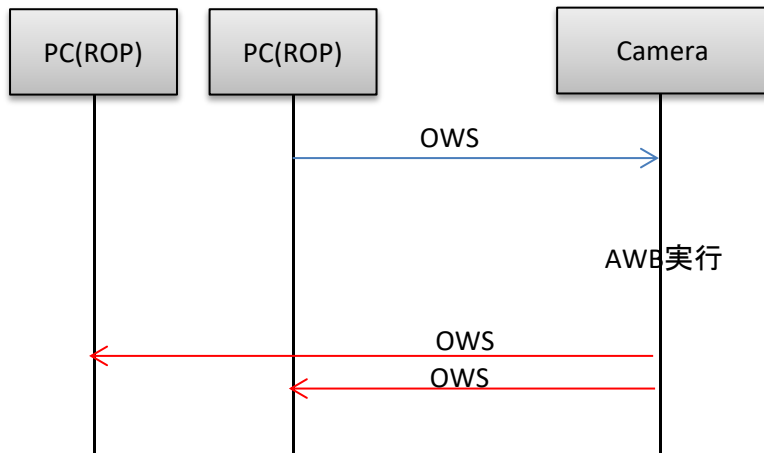

IP

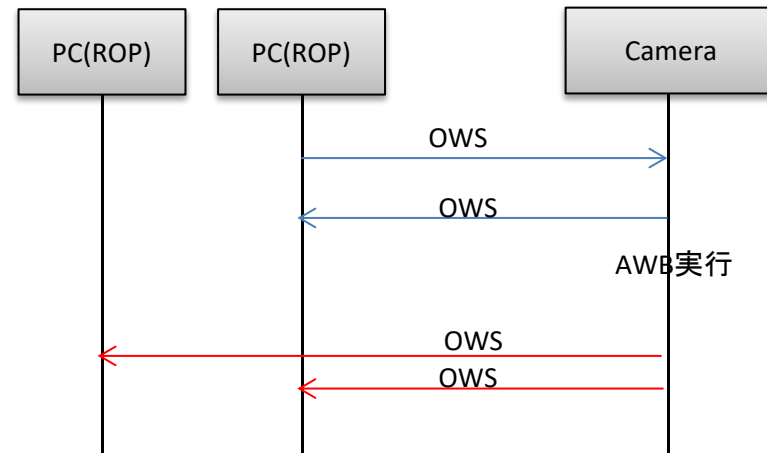

6-6.カメラ情報一括取得

IPからカメラ情報を一括で取得することができます。

【コマンドフォーマット】

[送信]

http://[IP Address]/live/camdata.html

[受信]

200 OK “カメラ情報”

カメラ情報に含まれる情報については9章参照

【シーケンス】

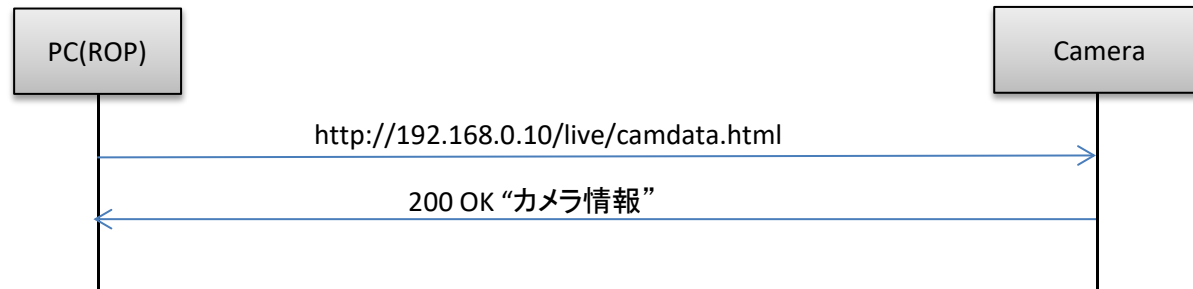

7.エラー返信

カメラで制御/問合せコマンドに対するエラーは、以下のER1、ER2、ER3の3種類のエラーがあります。

回転台コマンドの場合

▼ER1(未サポートコマンド)

カメラで未サポートのコマンドを受信した場合ER1で応答します。
例: 存在しないコマンド#AXを実行した際のシーケンス

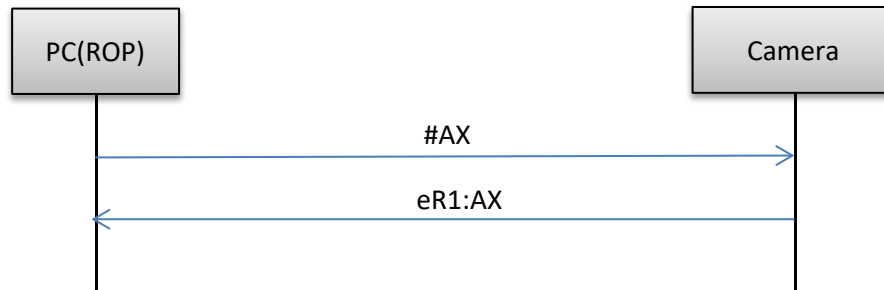

▼ER2(Busy状態)

Standby中など、カメラがBusy状態にある場合ER2で応答します

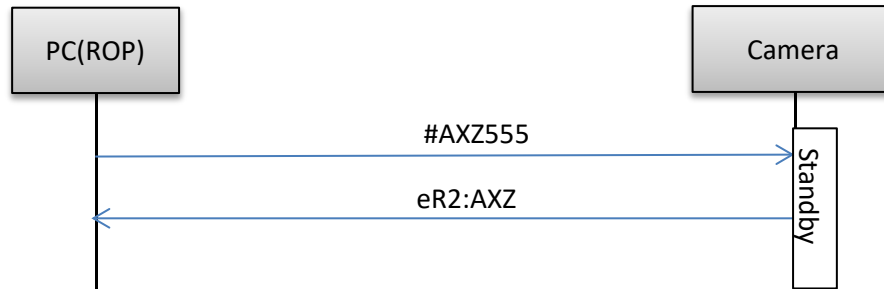

カメラコマンドの場合

▼ER1(未サポートコマンド)

カメラで未サポートのコマンドを受信した場合ER1で応答します。
例: 存在しないコマンドXFを実行した際のシーケンス

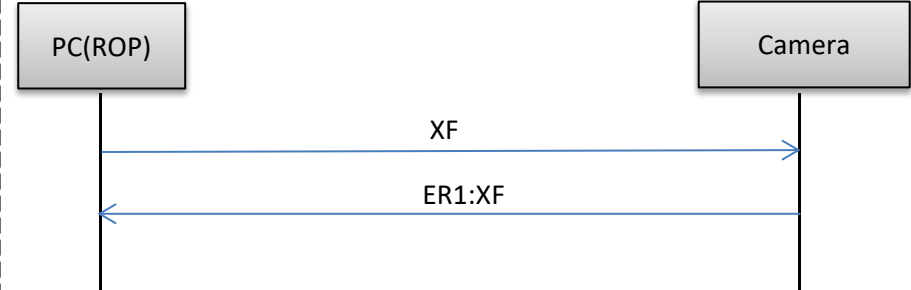

▼ER2(Busy状態)

Standby中など、カメラがBusy状態にある場合ER2で応答します

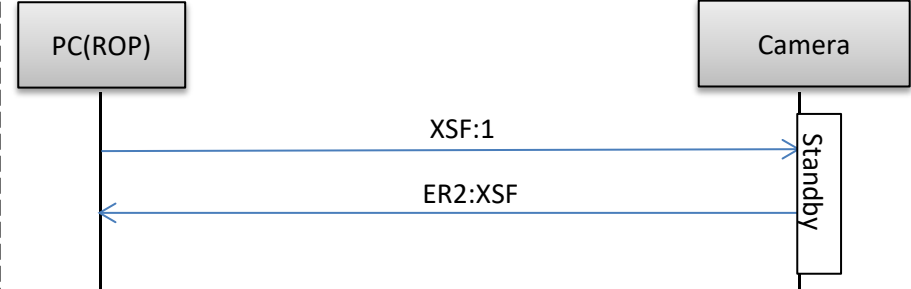

▼ER3(パラメータエラー)

コマンドのData値が範囲外だった場合はER3で応答します
例:「#AXZ(Zoom設定)」コマンドのData値を範囲外の「000」で実行

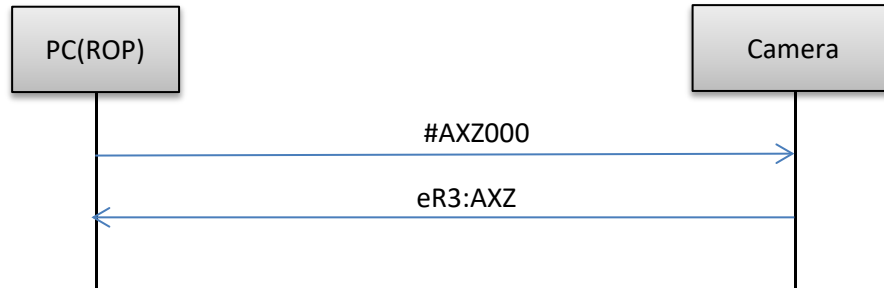

▼ER3(パラメータエラー)

コマンドのData値が範囲外だった場合はER3で応答します
例:「OGU(ゲイン設定)」コマンドのData値を範囲外の「90」で実行

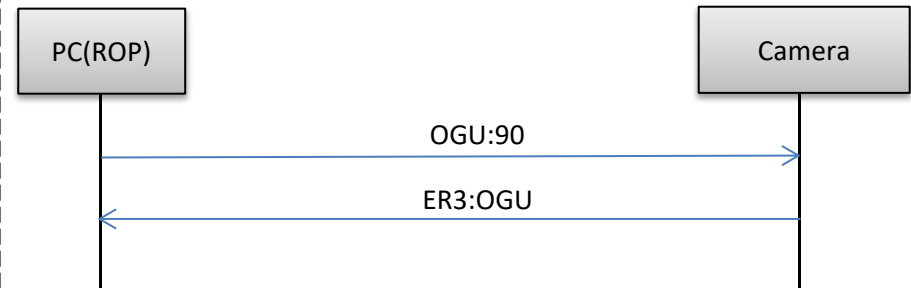

8. AW-UE160 メニュー・コマンド対応表

メニュー	コマンド	備考
BASIC CONFIG		
FREQUENCY	OSE:77	設定変更すると、自動的に再起動する
FORMAT	OSA:87	
SFP+ MODE	OSL:00	設定変更すると、自動的に再起動する
V-LOG	OSJ:56	HDRがONの時は制御不可 (ER2応答) とし、問い合わせにはOFFで応答する。
V-LOG PAINT SW	OSL:01	V-LOGがOFFの時は制御不可 (ER2応答) とし、問い合わせにはOFFで応答する。
HDR	OSI:2C	V-LOGがONの時は制御不可 (ER2応答) とし、問い合わせにはOFFで応答する。
GAMUT	OSL:02	HDRがOFFの時は制御不可 (ER2応答) とし、問い合わせにはNORMALで応答する。
SHOOTING MODE		
SERIAL CONNECTION		
BAUD RATE	OVP:04	TRACKING DATA OUTPUT - SERIALがONの時は制御不可 (ER2応答)
BAR	DCB	
COLOR BAR TYPE	OSD:BA	
TONE	OSJ:27	
TALLY	TLR #DA TLG TLY #TAA	TLR/#DAは同義。更新通知は両方出る。
TALLY	#TAE	
TALLY BRIGHTNESS	OSA:D3	
TALLY GUARD	OSL:04	
TALLY LED LIMIT		
R	OSJ:D9	
G	OSJ:DA	
Y	OSL:05	
EXTERNAL OUTPUT		
OUTPUT1	OSJ:41	
OUTPUT2	OSJ:42	
TSL5.0		
INDEX NO.	-	
PORT	-	
SYNC SIGNAL		
REF SIGNAL	OSL:08	未アクティベート時、12Gモードで起動時、ST2110がOFF時は制御不可 (ER2応答)。問い合わせに対しては固定値 (SDI) で応答する。
GEN-LOCK		
H PHASE-COARSE	OSL:09	REF SIGNALがPTPの時は制御不可 (ER2応答)
H PHASE-FINE	OSL:0A	REF SIGNALがPTPの時は制御不可 (ER2応答)
BAR ID		
BAR ID	OSD:BE	SFP+ MODEが「ST2110 JPEG XS」の時は制御不可 (ER2応答)
BRIGHTNESS	OSL:0B	
ID1 POSITION V	OSL:0C	
ID1 POSITION H	OSL:0D	
ID1	OSL:0E	
ID2 POSITION V	OSL:0F	
ID2 POSITION H	OSL:10	
ID2	OSL:11	
OFFSET V	OSL:12	
OFFSET H	OSL:13	
NETWORK		
LAN		
DHCP	-	
IP ADDRESS	-	
SUBNET MASK	-	
DEFAULT GATEWAY	-	
MAC ADDRESS	-	
SFP+		
DHCP	-	
IP ADDRESS	-	
SUBNET MASK	-	
DEFAULT GATEWAY	-	
MAC ADDRESS	-	
COMMON SETTING		
DNS	-	
PRIMARY	-	
SECONDARY	-	
DOMAIN	-	
HTTP PORT	-	

メニュー		コマンド	備考
HTTPS PORT		-	
OUTPUT			
12G SDI OUT/SFP+			
	FORMAT SELECT	OSJ:1E	
	HDR OUTPUT SELECT	OSJ:1F	・HDRがOFFの時は制御不可 (ER2応答) ・HDR(2020)はGAMUTが"WIDE_G2"の時のみ選択可能
	V-LOG OUTPUT SELECT	OSJ:57	V-LOGがOFFの時は制御不可 (ER2応答)
	OUTPUT ITEM	OSL:14	
	CHAR	OSE:7B	
	3G SDI	OSJ:20	12G SDI OUT/SFP+ のFORMAT SELECTが、 1080/59.94pまたは1080/50p以外の時は制御不可 (ER2応答)
3G SDI OUT1			
	FORMAT SELECT	OSJ:21	
	HDR OUTPUT SELECT	OSJ:22	・HDRがOFFの時は制御不可 (ER2応答) ・HDR(2020)はGAMUTが"WIDE_G2"の時のみ選択可能
	V-LOG OUTPUT SELECT	OSJ:58	V-LOGがOFFの時は制御不可 (ER2応答)
	OUTPUT ITEM	OSL:15	
	CHAR	OSE:7B	
	3G SDI	OSI:29	3G SDI OUT1 のFORMAT SELECTが、 1080/59.94pまたは1080/50p以外の時は制御不可 (ER2応答)
3G SDI OUT2/PM			
	OUTPUT SELECT	OSL:17	・UHD CROPがCROP(720)の時は制御不可 (ER2応答) ・未アクティベート時、12Gモード時は制御不可 (ER2応答) ・排他時は問い合わせには"CAM"で応答する。
	FORMAT SELECT	OSJ:23	3G SDI OUT2/PM > OUTPUT SELECTがRETURNの時は制御不可 (ER2応答)とし、問い合わせに"IP SIGNAL > ST2110 > RET VIDEO RX"と同等のパラメータで応答する。
	HDR OUTPUT SELECT	OSJ:24	・HDRがOFFの時は制御不可 (ER2応答) ・HDR(2020)はGAMUTが"WIDE_G2"の時のみ選択可能
	V-LOG OUTPUT SELECT	OSJ:59	V-LOGがOFFの時は制御不可 (ER2応答)
	OUTPUT ITEM	OSL:18	
	CHAR	OSE:7B	
	3G SDI	OSL:1A	3G SDI OUT2 のFORMAT SELECTが、 1080/59.94pまたは1080/50p以外の時は制御不可 (ER2応答)
HDMI			
	FORMAT SELECT	OSJ:25	
	HDR OUTPUT SELECT	OSJ:26	・HDRがOFFの時は制御不可 (ER2応答) ・HDR(2020)はGAMUTが"WIDE_G2"の時のみ選択可能
	V-LOG OUTPUT SELECT	OSJ:5A	V-LOGがOFFの時は制御不可 (ER2応答)
	VIDEO SAMPLING	OSE:68	HDMI - FORMAT SELECTが、2160/59.94pまたは2160/50pの時 のみ選択可能とし、それ以外の時は「4:2:2/10bit」固定とする
	CHAR	OSE:7B	
RETURN			
	RETURN1 ID	OSL:1B	未アクティベート時は制御不可 (ER2応答)
AUDIO			
	AUDIO	OSA:D0	
INPUT1 SETTING			
	INPUT SELECT	OSL:1C	
	MIC GAIN	OSL:1D	INPUT SELECTがLINEの時は制御不可 (ER2応答)
	LINE LEVEL	OSA:D4	INPUT SELECTがMIC, MIC+48Vの時は制御不可 (ER2応答)
INPUT2 SETTING			
	INPUT SELECT	OSL:1C	
	MIC GAIN	OSL:1D	INPUT SELECTがLINEの時は制御不可 (ER2応答)
	LINE LEVEL	OSA:D4	INPUT SELECTがMIC, MIC+48Vの時は制御不可 (ER2応答)
OUTPUT SETTING			
	CH SELECT	OSL:1E	
	CH1 VOLUME LEVEL	OSA:D5	
	CH2 VOLUME LEVEL	OSA:D5	
	HEAD ROOM	OSA:D6	
ST2110 AUDIO FORMAT			
	CH1	-	
	CH2	-	
IP SIGNAL			
NDI			
	FORMAT SELECT	OSL:21	・UE163MCにおいて、NDIアクティベーションが未の時は制御不可 (ER2応答) ・SFP+ MODEが「ST2110 JPEG XS」の時は制御不可 (ER2応答)
IP (H. 264/H. 265)			
	OUTPUT ITEM	OSL:23	
	CHAR	OSE:7B	
ST2110			
	MOIP MODE	-	
MAIN VIDEO TX			

メニュー		コマンド	備考
	FORMAT	QSL:AA	<ul style="list-style-type: none"> ・未アクティベート時およびMOIP MODEがOFFの時は制御不可 (ER2応答) とし、問い合わせにはDISABLEで応答する。 ・システムフォーマットが1080/59.94p or 1080/50pの以外の時は制御不可 (ER2応答) ・SFP+ MODEが「ST2110 JPEG XS」の時は制御不可 (ER2応答)
	CROP VIDEO TX		
	FORMAT	QSL:AC	<ul style="list-style-type: none"> ・未アクティベート時、MOIP MODEがOFFの時およびUHD CROPがOFFの時は問い合わせにはODISABLEで応答する。 ・SFP+ MODEが「ST2110 JPEG XS」の時は制御不可 (ER2応答)
	MONITOR VIDEO TX		
	FORMAT	QSL:AD	<ul style="list-style-type: none"> ・未アクティベート時、MOIP MODEがOFFの時および3G SDI OUT2 >OUTPUT SELECT=RETURNの時は問い合わせにはODISABLEで応答する。 ・SFP+ MODEが「ST2110 JPEG XS」の時は制御不可 (ER2応答)
	RET VIDEO RX		
	FORMAT	OSL:B4	<ul style="list-style-type: none"> ・未アクティベート時およびMOIP MODEがOFFの時は問い合わせにはODISABLEで応答する。 ・SFP+ MODEが「ST2110 JPEG XS」の時は制御不可 (ER2応答)
	JPEG XS TX VIDEO SELECT	OSL:C8	<ul style="list-style-type: none"> ・SFP+ MODEが「ST2110 JPEG XS」の時は制御不可 (ER2応答)
	MAIN VIDEO JPEG XS TX		
	FORMAT	OSL:C9	<ul style="list-style-type: none"> ・SFP+ MODEが「ST2110 JPEG XS」の時は制御不可 (ER2応答)
	CROP VIDEO JPEG XS TX		
	FORMAT	OCL:CA	<ul style="list-style-type: none"> ・SFP+ MODEが「ST2110 JPEG XS」の時は制御不可 (ER2応答)
	RET VIDEO JPEG XS RX		
	FORMAT	OSL:CB	<ul style="list-style-type: none"> ・SFP+ MODEが「ST2110 JPEG XS」の時は制御不可 (ER2応答)
	PAINT		
	AUTO		
	AGC	OSL:26	
	AUTO IRIS	ORS #D3	ORS/#D3は同義。更新通知は両方出る。
	ATW	OSL:2A	
	AUTO SHUTTER	OSL:2E	SHUTTER SW : OFF 時は制御不可 (ER2応答) とし、問い合わせにはOFFで応答する。
	KNEE MODE	OSL:46	<ul style="list-style-type: none"> ・V-LOG : ON時は制御不可 (ER2応答) ・HDR : ON時は制御不可 (ER2応答) ・KNEE : OFF時は制御不可 (ER2応答)
	GAIN SETTING		
	GAIN	OSL:25 OGU	
	AGC	OSL:26	
	AGC MAX GAIN	OSD:69	
	FRAME MIX SW	OSL:27	<ul style="list-style-type: none"> ・SHUTTER SW : ON時はFRAME MIXは無効とし制御不可 (ER2応答) とし、問い合わせにはOFFで応答する。 ・FORMATが以下の時はFRAME MIXは無効とし制御不可 (ER2応答) とし、問い合わせにはOFFで応答する。 <ul style="list-style-type: none"> ・2160/29.97p ・2160/23.98p ・2160/24p ・2160/25p ・1080/119.88p ・1080/29.97p ・1080/23.98p ・1080/23.98p ・1080/24p ・1080/25p ・1080/100p
	FRAME MIX	OSL:28 OSA:65	FRAME MIX : OFF時は制御不可 (ER2応答)
	DAY/NIGHT	#D6	
	IRIS		
	AUTO IRIS	ORS #D3	ORS/#D3は同義。更新通知は両方出る。
	WINDOW SELECT	OSJ:02 OSL:CC OSL:CD	
	PICTURE LEVEL	OSD:48	"AUTO IRIS:OFF" かつ "AUTO SHUTTER:OFF" かつ "AGC:OFF" の場合は制御不可 (ER2応答)
	PEAK RATIO	OSL:29	
	AUTO IRIS CLOSE LIMIT	OSJ:C0	
	IRIS SPEED	OSJ:01	
	W/B BAL SETTING	OWS OAS	<ul style="list-style-type: none"> ・DAY/NIGHT:NIGHTの時、AWB実行不可 (ABBは実行可能)
	ATW	OSL:2A	
	WHITE BALANCE MODE	OSL:2B OAW	ATW : ON時は制御不可 (ER2応答)

メニュー		コマンド	備考
	W. BAL VAR	OSI:20 OSI:1E OSI:1F	・ WHITE BALANCE MODEがVAR以外の時は制御不可 (ER2応答) ・ ATW : ON時は制御不可 (ER2応答)
	ATW SPEED	OSI:25	ATW : OFF時は制御不可 (ER2応答)
	ATW TARGET R	OSJ:0D	ATW : OFF時は制御不可 (ER2応答)
	ATW TARGET B	OSJ:0E	ATW : OFF時は制御不可 (ER2応答)
	SHOCKLESS WB SW	OSL:2C	
	SHOCKLESS WB SPEED	OSL:2D	
SHUTTER SPEED			
	SHUTTER SW	OSG:59	
	AUTO SHUTTER	OSL:2E	SHUTTER SW : OFF 時は制御不可 (ER2応答) とし、問い合わせにはOFFで応答する。
	AUTO SHUTTER LIMIT	OSD:BF	SHUTTER SW : OFF またはAUTO SHUTTER : OFF時は制御不可 (ER2応答)
	SHUTTER MODE	OSG:5A OSJ:03	
	SHUTTER SPEED	OSJ:06 OSJ:04 OSJ:05	・ SHUTTER MODE : STEP以外の時は制御不可 (ER2応答)
	SYNCHRO SCAN	OSJ:09 OSJ:07 OSJ:08	・ SHUTTER MODE : SYNCHRO以外の時は制御不可 (ER2応答)
PEDESTAL			
	MASTER PEDESTAL	OSJ:0F	V-LOG : ONかつV-LOG PAINT SW : OFF時は制御不可 (ER2応答)
	R PEDESTAL	OSG:4C	V-LOG : ONかつV-LOG PAINT SW : OFF時は制御不可 (ER2応答)
	G PEDESTAL	OSG:4D	V-LOG : ONかつV-LOG PAINT SW : OFF時は制御不可 (ER2応答)
	B PEDESTAL	OSG:4E	V-LOG : ONかつV-LOG PAINT SW : OFF時は制御不可 (ER2応答)
	PEDESTAL OFFSET	OSJ:11	V-LOG : ONかつV-LOG PAINT SW : OFF時は制御不可 (ER2応答)
CHROMA			
	CHROMA LEVEL SW	OSG:93	V-LOG : ONかつV-LOG PAINT SW : OFF時は制御不可 (ER2応答)
	CHROMA LEVEL	OSL:B0 OSD:B0	・ V-LOG : ONかつV-LOG PAINT SW : OFF時は制御不可 (ER2応答)
COLOR TEMP SETTING			
COLOR TEMP ACH/BCH			
	COLOR TEMP ACH	OSJ:4A OSJ:48 OSJ:49	V-LOG PAINTの同名メニューと同一コマンド
	R GAIN ACH	OSJ:4B	V-LOG PAINTの同名メニューと同一コマンド
	B GAIN ACH	OSJ:4C	V-LOG PAINTの同名メニューと同一コマンド
	G AXIS ACH	OSJ:4D	V-LOG PAINTの同名メニューと同一コマンド
	COLOR TEMP BCH	OSL:2F OSL:30 OSL:31	V-LOG PAINTの同名メニューと同一コマンド
	R GAIN BCH	OSL:32	V-LOG PAINTの同名メニューと同一コマンド
	B GAIN BCH	OSL:33	V-LOG PAINTの同名メニューと同一コマンド
	G AXIS BCH	OSL:34	V-LOG PAINTの同名メニューと同一コマンド
RGB GAIN CONTROL SETTING			
	G GAIN REL CONTROL SW	OSL:35	V-LOG : ONかつV-LOG PAINT SW : OFF時は制御不可 (ER2応答) とし、問い合わせにはOFFで応答する。
RGB GAIN PRESET			
	R GAIN	OSL:36	・ WHITE BALANCE MODEがAWB A、AWB Bの時は制御不可 (ER2応答) ・ V-LOG : ONかつV-LOG PAINT SW : OFF時は制御不可 (ER2応答)
	G GAIN	OSL:37	・ WHITE BALANCE MODEがAWB A、AWB Bの時は制御不可 (ER2応答) ・ V-LOG : ONかつV-LOG PAINT SW : OFF時は制御不可 (ER2応答)
	B GAIN	OSL:38	・ WHITE BALANCE MODEがAWB A、AWB Bの時は制御不可 (ER2応答) ・ V-LOG : ONかつV-LOG PAINT SW : OFF時は制御不可 (ER2応答)
RGB GAIN ACH/BCH			
	R GAIN ACH	OSL:39	V-LOG : ONかつV-LOG PAINT SW : OFF時は制御不可 (ER2応答)
	G GAIN ACH	OSL:3A	V-LOG : ONかつV-LOG PAINT SW : OFF時は制御不可 (ER2応答)
	B GAIN ACH	OSL:3B	V-LOG : ONかつV-LOG PAINT SW : OFF時は制御不可 (ER2応答)
	GAIN OFFSET ACH	OSJ:0C	V-LOG : ONかつV-LOG PAINT SW : OFF時は制御不可 (ER2応答)
	R GAIN BCH	OSL:3C	V-LOG : ONかつV-LOG PAINT SW : OFF時は制御不可 (ER2応答)
	G GAIN BCH	OSL:3D	V-LOG : ONかつV-LOG PAINT SW : OFF時は制御不可 (ER2応答)
	B GAIN BCH	OSL:3E	V-LOG : ONかつV-LOG PAINT SW : OFF時は制御不可 (ER2応答)
	GAIN OFFSET BCH	OSL:3F	V-LOG : ONかつV-LOG PAINT SW : OFF時は制御不可 (ER2応答)
FLARE			
	FLARE	OSA:11	V-LOG : ONかつV-LOG PAINT SW : OFF時は制御不可 (ER2応答) とし、問い合わせにはOFFで応答する。
	MASTER FLARE	OSL:40	・ V-LOG : ONかつV-LOG PAINT SW : OFF時は制御不可 (ER2応答)
	R FLARE	OSL:41	・ V-LOG : ONかつV-LOG PAINT SW : OFF時は制御不可 (ER2応答)
	G FLARE	OSL:42	・ V-LOG : ONかつV-LOG PAINT SW : OFF時は制御不可 (ER2応答)

メニュー		コマンド	備考
	B FLARE	OSL:43	・V-LOG : ONかつV-LOG PAINT SW : OFF時は制御不可 (ER2応答)
GAMMA/BLACK GAMMA			
	GAMMA	OSA:0A	・V-LOG : ON時は制御不可 (ER2応答) とし、問い合わせにはONで応答する。 ・HDR : ON時は制御不可 (ER2応答) とし、問い合わせにはONで応答する。
	GAMMA MODE SELECT	OSJ:D7	・V-LOG : ON時は制御不可 (ER2応答) ・HDR : ON時は制御不可 (ER2応答) ・GAMMA : OFF時は制御不可 (ER2応答)
	MASTER GAMMA	OSA:6A	・V-LOG : ON時は制御不可 (ER2応答) ・HDR : ON時は制御不可 (ER2応答) ・GAMMA : OFF時は制御不可 (ER2応答)
	R GAMMA	OSI:35	・V-LOG : ON時は制御不可 (ER2応答) ・HDR : ON時は制御不可 (ER2応答) ・GAMMA : OFF時は制御不可 (ER2応答)
	B GAMMA	OSI:36	・V-LOG : ON時は制御不可 (ER2応答) ・HDR : ON時は制御不可 (ER2応答) ・GAMMA : OFF時は制御不可 (ER2応答)
	BLACK GAMMA	OSA:0B	・V-LOG : ON時は制御不可 (ER2応答) ・HDR : ON時は制御不可 (ER2応答) ・GAMMA : OFF時は制御不可 (ER2応答)
	MASTER BLACK GAMMA	OSA:07	・V-LOG : ON時は制御不可 (ER2応答) ・HDR : ON時は制御不可 (ER2応答) ・GAMMA : OFF時は制御不可 (ER2応答) ・BLACK GAMMA : OFF時は制御不可 (ER2応答)
	R BLACK GAMMA	OSA:08	・V-LOG : ON時は制御不可 (ER2応答) ・HDR : ON時は制御不可 (ER2応答) ・GAMMA : OFF時は制御不可 (ER2応答) ・BLACK GAMMA : OFF時は制御不可 (ER2応答)
	B BLACK GAMMA	OSA:09	・V-LOG : ON時は制御不可 (ER2応答) ・HDR : ON時は制御不可 (ER2応答) ・GAMMA : OFF時は制御不可 (ER2応答) ・BLACK GAMMA : OFF時は制御不可 (ER2応答)
	BLACK GAMMA RANGE	OSJ:1B	・V-LOG : ON時は制御不可 (ER2応答) ・HDR : ON時は制御不可 (ER2応答) ・GAMMA : OFF時は制御不可 (ER2応答) ・BLACK GAMMA : OFF時は制御不可 (ER2応答)
	INITIAL GAMMA	OSL:44	・V-LOG : ON時は制御不可 (ER2応答) ・HDR : ON時は制御不可 (ER2応答) ・GAMMA MODE SELECTがNORMAL, CINEMA1, CINEMA2の時は制御不可 (ER2応答) ・GAMMA : OFF時は制御不可 (ER2応答)
KNEE			
	KNEE	OSL:45	・V-LOG : ON時は制御不可 (ER2応答) とし、問い合わせにはOFFで応答する。 ・HDR : ON時は制御不可 (ER2応答) とし、問い合わせにはOFFで応答する。
	KNEE MODE	OSL:46 OSA:2D	・V-LOG : ON時は制御不可 (ER2応答) ・HDR : ON時は制御不可 (ER2応答) ・KNEE : OFF時は制御不可 (ER2応答)
	KNEE MASTER POINT	OSA:20	・KNEE MODE : AUTO時は制御不可 (ER2応答)
	KNEE R POINT	OSA:22	・KNEE MODE : AUTO時は制御不可 (ER2応答)
	KNEE B POINT	OSA:23	・KNEE MODE : AUTO時は制御不可 (ER2応答) ・V-LOG : ON時は制御不可 (ER2応答) ・HDR : ON時は制御不可 (ER2応答) ・KNEE : OFF時は制御不可 (ER2応答)
	KNEE MASTER SLOPE	OSA:24	・KNEE MODE : AUTO時は制御不可 (ER2応答) ・V-LOG : ON時は制御不可 (ER2応答) ・HDR : ON時は制御不可 (ER2応答) ・KNEE : OFF時は制御不可 (ER2応答)
	KNEE R SLOPE	OSA:26	・KNEE MODE : AUTO時は制御不可 (ER2応答) ・V-LOG : ON時は制御不可 (ER2応答) ・HDR : ON時は制御不可 (ER2応答) ・KNEE : OFF時は制御不可 (ER2応答)
	KNEE B SLOPE	OSA:27	・KNEE MODE : AUTO時は制御不可 (ER2応答) ・V-LOG : ON時は制御不可 (ER2応答) ・HDR : ON時は制御不可 (ER2応答) ・KNEE : OFF時は制御不可 (ER2応答)
	AUTO KNEE RESPONSE	OSG:97	・V-LOG : ON時は制御不可 (ER2応答) ・HDR : ON時は制御不可 (ER2応答) ・KNEE : OFF時は制御不可 (ER2応答)
WHITE CLIP			
	WHITE CLIP	OSA:2E	・V-LOG : ON時は制御不可 (ER2応答) とし、問い合わせにはOFFで応答する。 ・HDR : ON時は制御不可 (ER2応答) とし、問い合わせにはOFFで応答する。

メニュー		コマンド	備考
	MASTER WHITE CLIP LEVEL	OSA:2A	<ul style="list-style-type: none"> ・ V-LOG : ON時は制御不可 (ER2応答) ・ HDR : ON時は制御不可 (ER2応答) ・ WHITE CLIP : OFF時は制御不可 (ER2応答)
	R WHITE CLIP LEVEL	OSL:47	<ul style="list-style-type: none"> ・ V-LOG : ON時は制御不可 (ER2応答) ・ HDR : ON時は制御不可 (ER2応答) ・ WHITE CLIP : OFF時は制御不可 (ER2応答)
	B WHITE CLIP LEVEL	OSL:48	<ul style="list-style-type: none"> ・ V-LOG : ON時は制御不可 (ER2応答) ・ HDR : ON時は制御不可 (ER2応答) ・ WHITE CLIP : OFF時は制御不可 (ER2応答)
	HI-COLOR	OSL:49	<ul style="list-style-type: none"> ・ V-LOG : ON時は制御不可 (ER2応答) ・ HDR : ON時は制御不可 (ER2応答)
	HI-COLOR LEVEL	OSL:4A	<ul style="list-style-type: none"> ・ V-LOG : ON時は制御不可 (ER2応答) ・ HDR : ON時は制御不可 (ER2応答)
DRS			
	DRS	OSA:0D	V-LOG : ON時は制御不可 (ER2応答) とし、問い合わせにはOFFで応答する。
	EFFECT DEPTH	OSL:4B	V-LOG : ON時は制御不可 (ER2応答)
DETAIL SETTING			
	DETAIL	ODT	V-LOG : ONかつV-LOG PAINT SW : OFF時は制御不可 (ER2応答) とし、問い合わせにはOFFで応答する。
	MASTER DETAIL	OSA:30	<ul style="list-style-type: none"> ・ DETAILが"OFF"時は制御不可 (ER2応答) ・ V-LOG : ONかつV-LOG PAINT SW : OFF時は制御不可 (ER2応答)
	PEAK FREQUENCY	OSG:30	<ul style="list-style-type: none"> ・ DETAILが"OFF"時は制御不可 (ER2応答) ・ V-LOG : ONかつV-LOG PAINT SW : OFF時は制御不可 (ER2応答)
	CRISP	OSD:22	<ul style="list-style-type: none"> ・ DETAILが"OFF"時は制御不可 (ER2応答) ・ V-LOG : ONかつV-LOG PAINT SW : OFF時は制御不可 (ER2応答)
	DETAIL GAIN(+)	OSA:38	<ul style="list-style-type: none"> ・ DETAILが"OFF"時は制御不可 (ER2応答) ・ V-LOG : ONかつV-LOG PAINT SW : OFF時は制御不可 (ER2応答)
	DETAIL GAIN(-)	OSA:39	<ul style="list-style-type: none"> ・ DETAILが"OFF"時は制御不可 (ER2応答) ・ V-LOG : ONかつV-LOG PAINT SW : OFF時は制御不可 (ER2応答)
	DETAIL CLIP(+)	OSG:40	<ul style="list-style-type: none"> ・ DETAILが"OFF"時は制御不可 (ER2応答) ・ V-LOG : ONかつV-LOG PAINT SW : OFF時は制御不可 (ER2応答)
	DETAIL CLIP(-)	OSG:41	<ul style="list-style-type: none"> ・ DETAILが"OFF"時は制御不可 (ER2応答) ・ V-LOG : ONかつV-LOG PAINT SW : OFF時は制御不可 (ER2応答)
	KNEE APERTURE LEVEL	OSG:3F	<ul style="list-style-type: none"> ・ DETAILが"OFF"時は制御不可 (ER2応答) ・ V-LOG : ONかつV-LOG PAINT SW : OFF時は制御不可 (ER2応答)
	DETAIL KNEE	OSL:4C	<ul style="list-style-type: none"> ・ DETAILが"OFF"時は制御不可 (ER2応答) ・ V-LOG : ONかつV-LOG PAINT SW : OFF時は制御不可 (ER2応答)
	LEVEL DEPENDENT SW	OSG:3E	<ul style="list-style-type: none"> ・ DETAILが"OFF"時は制御不可 (ER2応答) ・ V-LOG : ONかつV-LOG PAINT SW : OFF時は制御不可 (ER2応答)
	LEVEL DEPENDENT	OSD:26	<ul style="list-style-type: none"> ・ DETAILが"OFF"時は制御不可 (ER2応答) ・ V-LOG : ONかつV-LOG PAINT SW : OFF時は制御不可 (ER2応答)
	DARK DETAIL SW	OSL:4D	<ul style="list-style-type: none"> ・ DETAILが"OFF"時は制御不可 (ER2応答) ・ V-LOG : ONかつV-LOG PAINT SW : OFF時は制御不可 (ER2応答)
	DARK DETAIL	OSL:4E	<ul style="list-style-type: none"> ・ DETAILが"OFF"時は制御不可 (ER2応答) ・ V-LOG : ONかつV-LOG PAINT SW : OFF時は制御不可 (ER2応答)
DOWNCON SETTING			
CHROMA			
	CHROMA LEVEL SW	OSL:4F	<ul style="list-style-type: none"> ・ FORMATが4K以外の時は制御不可 (ER2応答) とし、問い合わせにはOFFで応答する。 ・ V-LOG : ONかつV-LOG PAINT SW : OFF時は制御不可 (ER2応答) とし、問い合わせにはOFFで応答する。
	CHROMA LEVEL	OSL:50	<ul style="list-style-type: none"> ・ FORMATが4K以外の時は制御不可 (ER2応答) ・ V-LOG : ONかつV-LOG PAINT SW : OFF時は制御不可 (ER2応答)
DETAIL SETTING			
	DETAIL	OSJ:14	<ul style="list-style-type: none"> ・ FORMATが4K以外の時は制御不可 (ER2応答) とし、問い合わせにはOFFで応答する。 ・ V-LOG : ONかつV-LOG PAINT SW : OFF時は制御不可 (ER2応答) とし、問い合わせにはOFFで応答する。
	MASTER DETAIL	OSJ:15	<ul style="list-style-type: none"> ・ FORMATが4K以外の時は制御不可 (ER2応答) ・ V-LOG : ONかつV-LOG PAINT SW : OFF時は制御不可 (ER2応答)
	H DETAIL LEVEL	OSL:51	<ul style="list-style-type: none"> ・ FORMATが4K以外の時は制御不可 (ER2応答) ・ V-LOG : ONかつV-LOG PAINT SW : OFF時は制御不可 (ER2応答)
	V DETAIL LEVEL	OSJ:17	<ul style="list-style-type: none"> ・ FORMATが4K以外の時は制御不可 (ER2応答) ・ V-LOG : ONかつV-LOG PAINT SW : OFF時は制御不可 (ER2応答)
	PEAK FREQUENCY	OSL:52	<ul style="list-style-type: none"> ・ FORMATが4K以外の時は制御不可 (ER2応答) ・ V-LOG : ONかつV-LOG PAINT SW : OFF時は制御不可 (ER2応答)
	V DETAIL FREQUENCY	OSL:53	<ul style="list-style-type: none"> ・ FORMATが4K以外の時は制御不可 (ER2応答) ・ V-LOG : ONかつV-LOG PAINT SW : OFF時は制御不可 (ER2応答)

メニュー		コマンド	備考
	CRISP	OSL:54	・ FORMATが4K以外の時は制御不可 (ER2応答) ・ V-LOG : ONかつV-LOG PAINT SW : OFF時は制御不可 (ER2応答)
	DETAIL CLIP(+)	OSL:57	・ FORMATが4K以外の時は制御不可 (ER2応答) ・ V-LOG : ONかつV-LOG PAINT SW : OFF時は制御不可 (ER2応答)
	DETAIL CLIP(-)	OSL:58	・ FORMATが4K以外の時は制御不可 (ER2応答) ・ V-LOG : ONかつV-LOG PAINT SW : OFF時は制御不可 (ER2応答)
	KNEE APERTURE LEVEL	OSL:5A	・ FORMATが4K以外の時は制御不可 (ER2応答) ・ V-LOG : ONかつV-LOG PAINT SW : OFF時は制御不可 (ER2応答)
	DETAIL KNEE	OSL:5B	・ FORMATが4K以外の時は制御不可 (ER2応答) ・ V-LOG : ONかつV-LOG PAINT SW : OFF時は制御不可 (ER2応答)
	LEVEL DEPENDENT SW	OSL:5C	・ FORMATが4K以外の時は制御不可 (ER2応答) ・ V-LOG : ONかつV-LOG PAINT SW : OFF時は制御不可 (ER2応答)
	LEVEL DEPENDENT	OSL:5D	・ FORMATが4K以外の時は制御不可 (ER2応答) ・ V-LOG : ONかつV-LOG PAINT SW : OFF時は制御不可 (ER2応答)
	DARK DETAIL SW	OSL:5E	・ FORMATが4K以外の時は制御不可 (ER2応答) ・ V-LOG : ONかつV-LOG PAINT SW : OFF時は制御不可 (ER2応答)
	DARK DETAIL	OSL:5F	・ FORMATが4K以外の時は制御不可 (ER2応答) ・ V-LOG : ONかつV-LOG PAINT SW : OFF時は制御不可 (ER2応答)
SKIN TONE DETAIL SETTING			
	SKIN TONE DETAIL	OSL:60	・ FORMATが4K以外の時は制御不可 (ER2応答) とし、問い合わせにはOFFで応答する。 ・ V-LOG : ONかつV-LOG PAINT SW : OFF時は制御不可 (ER2応答) とし、問い合わせにはOFFで応答する。
	MEMORY SELECT	OSL:B1	・ FORMATが4K以外の時は制御不可 (ER2応答) ・ V-LOG : ONかつV-LOG PAINT SW : OFF時は制御不可 (ER2応答)
	ZEBRA	OSL:61	・ FORMATが4K以外の時は制御不可 (ER2応答) ・ V-LOG : ONかつV-LOG PAINT SW : OFF時は制御不可 (ER2応答) ・ SKIN TONE DETAIL SETTING - ZEBRAがON時は制御不可 (ER2応答)
	ZEBRA EFFECT MEMORY	OSL:62	・ FORMATが4K以外の時は制御不可 (ER2応答) ・ V-LOG : ONかつV-LOG PAINT SW : OFF時は制御不可 (ER2応答)
	SKIN TONE EFFECT MEMORY	OSL:63	・ FORMATが4K以外の時は制御不可 (ER2応答) ・ V-LOG : ONかつV-LOG PAINT SW : OFF時は制御不可 (ER2応答)
	SKIN TONE CRISP	OSL:64	・ FORMATが4K以外の時は制御不可 (ER2応答) ・ V-LOG : ONかつV-LOG PAINT SW : OFF時は制御不可 (ER2応答)
	I CENTER	OSL:65	・ FORMATが4K以外の時は制御不可 (ER2応答) ・ V-LOG : ONかつV-LOG PAINT SW : OFF時は制御不可 (ER2応答)
	I WIDTH	OSL:66	・ FORMATが4K以外の時は制御不可 (ER2応答) ・ V-LOG : ONかつV-LOG PAINT SW : OFF時は制御不可 (ER2応答)
	Q WIDTH	OSL:67	・ FORMATが4K以外の時は制御不可 (ER2応答) ・ V-LOG : ONかつV-LOG PAINT SW : OFF時は制御不可 (ER2応答)
	Q PHASE	OSL:68	・ FORMATが4K以外の時は制御不可 (ER2応答) ・ V-LOG : ONかつV-LOG PAINT SW : OFF時は制御不可 (ER2応答)
SKIN TONE DETAIL SETTING			
	SKIN TONE DETAIL	OSA:40	V-LOG : ONかつV-LOG PAINT SW : OFF時は制御不可 (ER2応答) とし、問い合わせにはOFFで応答する。
	MEMORY SELECT	OSL:69	V-LOG : ONかつV-LOG PAINT SW : OFF時は制御不可 (ER2応答)
	ZEBRA	OSA:49	・ V-LOG : ONかつV-LOG PAINT SW : OFF時は制御不可 (ER2応答) ・ DOWNCON SETTING - SKIN TONE DETAIL SETTING - ZEBRAがON時は制御不可 (ER2応答)
	ZEBRA EFFECT MEMORY	OSL:6A	V-LOG : ONかつV-LOG PAINT SW : OFF時は制御不可 (ER2応答)
	SKIN TONE EFFECT MEMORY	OSG:48	V-LOG : ONかつV-LOG PAINT SW : OFF時は制御不可 (ER2応答)
	SKIN TONE CRISP	OSG:49	・ V-LOG : ONかつV-LOG PAINT SW : OFF時は制御不可 (ER2応答)
	I CENTER	OSA:45	・ V-LOG : ONかつV-LOG PAINT SW : OFF時は制御不可 (ER2応答)
	I WIDTH	OSA:46	・ V-LOG : ONかつV-LOG PAINT SW : OFF時は制御不可 (ER2応答)
	Q WIDTH	OSA:47	・ V-LOG : ONかつV-LOG PAINT SW : OFF時は制御不可 (ER2応答)
	Q PHASE	OSG:4F	・ V-LOG : ONかつV-LOG PAINT SW : OFF時は制御不可 (ER2応答)
LINEAR MATRIX			
	PRESET MATRIX	OSE:31	V-LOG : ONかつV-LOG PAINT SW : OFF時は制御不可 (ER2応答) とし、問い合わせにはNORMALで応答する。
	MATRIX	OSA:84	V-LOG : ONかつV-LOG PAINT SW : OFF時は制御不可 (ER2応答) とし、問い合わせにはOFFで応答する。
	LINEAR MATRIX	OSL:6C	V-LOG : ONかつV-LOG PAINT SW : OFF時は制御不可 (ER2応答) とし、問い合わせにはOFFで応答する。
	LINEAR TABLE	OSA:00	V-LOG : ONかつV-LOG PAINT SW : OFF時は制御不可 (ER2応答)

メニュー		コマンド	備考
	MG R PHASE	OSD:85	・ COLOR CORRECT : OFF時は制御不可 (ER2応答) ・ V-LOG : ONかつV-LOG PAINT SW : OFF時は制御不可 (ER2応答)
	R PHASE	OSD:87	・ COLOR CORRECT : OFF時は制御不可 (ER2応答) ・ V-LOG : ONかつV-LOG PAINT SW : OFF時は制御不可 (ER2応答)
	R YE PHASE	OSD:89	・ COLOR CORRECT : OFF時は制御不可 (ER2応答) ・ V-LOG : ONかつV-LOG PAINT SW : OFF時は制御不可 (ER2応答)
	YE PHASE	OSD:8B	・ COLOR CORRECT : OFF時は制御不可 (ER2応答) ・ V-LOG : ONかつV-LOG PAINT SW : OFF時は制御不可 (ER2応答)
	YE G PHASE	OSD:8D	・ COLOR CORRECT : OFF時は制御不可 (ER2応答) ・ V-LOG : ONかつV-LOG PAINT SW : OFF時は制御不可 (ER2応答)
DNR			
	DNR	OSD:3A	V-LOG PAINTの同名メニューと同一コマンド
	DNR LEVEL	OSG:B5	・ V-LOG PAINTの同名メニューと同一コマンド ・ DNR : OFF時は制御不可 (ER2応答)
V-LOG PAINT			
COLOR TEMP SETTING			
COLOR TEMP ACH/BCH			
	COLOR TEMP ACH	OSJ:4A OSJ:48 OSJ:49	PAINT-COLOR TEMP SETTINGの同名メニューと同一コマンド
	R GAIN ACH	OSJ:4B	PAINT-COLOR TEMP SETTINGの同名メニューと同一コマンド
	B GAIN ACH	OSJ:4C	PAINT-COLOR TEMP SETTINGの同名メニューと同一コマンド
	G AXIS ACH	OSJ:4D	PAINT-COLOR TEMP SETTINGの同名メニューと同一コマンド
	COLOR TEMP BCH	OSL:2F OSL:30 OSL:31	PAINT-COLOR TEMP SETTINGの同名メニューと同一コマンド
	R GAIN BCH	OSL:32	PAINT-COLOR TEMP SETTINGの同名メニューと同一コマンド
	B GAIN BCH	OSL:33	PAINT-COLOR TEMP SETTINGの同名メニューと同一コマンド
	G AXIS BCH	OSL:34	PAINT-COLOR TEMP SETTINGの同名メニューと同一コマンド
DNR			
	DNR	OSD:3A	PAINT-DNRの同名メニューと同一コマンド
	DNR LEVEL	OSG:B5	・ PAINT-DNRの同名メニューと同一コマンド ・ DNR : OFF時は制御不可 (ER2応答)
HDR PAINT			
	HLG MODE	OSI:39	・ HDR : OFF時は制御不可 (ER2応答) とし、問い合わせにはFIXで応答する。
	SDR CONVERT MODE	OSI:3A	・ HDR : OFF時は制御不可 (ER2応答) とし、問い合わせにはFIXで応答する。
GAMMA/BLACK GAMMA			
	BLACK GAMMA	OSI:3C	・ HDR : OFFまたはHLG MODE : FIX時は制御不可 (ER2応答) とし、問い合わせにはOFFで応答する。
	MASTER BLACK GAMMA	OSI:3D	・ HDR : OFFまたはHLG MODE : FIX時は制御不可 (ER2応答)
	R BLACK GAMMA	OSI:3E	・ HDR : OFFまたはHLG MODE : FIX時は制御不可 (ER2応答)
	B BLACK GAMMA	OSI:3F	・ HDR : OFFまたはHLG MODE : FIX時は制御不可 (ER2応答)
KNEE			
	KNEE	OSI:40	・ HDR : OFFまたはHLG MODE : FIX時は制御不可 (ER2応答) とし、問い合わせにはOFFで応答する。
	KNEE POINT	OSI:41	・ HDR : OFFまたはHLG MODE : FIX時は制御不可 (ER2応答)
	KNEE SLOPE	OSI:42	・ HDR : OFFまたはHLG MODE : FIX時は制御不可 (ER2応答)
SDR CONVERT			
	GAIN	OSI:43	・ HDR : OFFまたはSDR CONVERT MODE : FIX時は制御不可 (ER2応答)
	POINT	OSL:88	・ HDR : OFFまたはSDR CONVERT MODE : FIX時は制御不可 (ER2応答)
	SLOPE	OSL:89	・ HDR : OFFまたはSDR CONVERT MODE : FIX時は制御不可 (ER2応答)
	BLACK OFFSET	OSL:8A	・ HDR : OFFまたはSDR CONVERT MODE : FIX時は制御不可 (ER2応答)
PAINT SWITCH			
	FLARE	OSA:11	V-LOG : ONかつV-LOG PAINT SW : OFF時は制御不可 (ER2応答) とし、問い合わせにはOFFで応答する。
	GAMMA	OSA:0A	・ V-LOG : ON時は制御不可 (ER2応答) とし、問い合わせにはONで応答する。 ・ HDR : ON時は制御不可 (ER2応答) とし、問い合わせにはONで応答する。
	BLACK GAMMA	OSA:0B	・ V-LOG : ON時は制御不可 (ER2応答) とし、問い合わせにはOFFで応答する。 ・ HDR : ON時は制御不可 (ER2応答) とし、問い合わせにはOFFで応答する。
	KNEE	OSL:45	・ V-LOG : ON時は制御不可 (ER2応答) とし、問い合わせにはOFFで応答する。 ・ HDR : ON時は制御不可 (ER2応答) とし、問い合わせにはOFFで応答する。
	WHITE CLIP	OSA:2E	・ V-LOG : ON時は制御不可 (ER2応答) とし、問い合わせにはOFFで応答する。 ・ HDR : ON時は制御不可 (ER2応答) とし、問い合わせにはOFFで応答する。

メニュー		コマンド	備考
	DRS	OSA:0D	V-LOG : ON時は制御不可 (ER2応答) とし、問い合わせにはOFFで応答する。
	DETAIL	ODT	V-LOG : ONかつV-LOG PAINT SW : OFF時は制御不可 (ER2応答)
	SKIN TONE DETAIL	OSA:40	V-LOG : ONかつV-LOG PAINT SW : OFF時は制御不可 (ER2応答) とし、問い合わせにはOFFで応答する。
	MATRIX	OSA:84	V-LOG : ONかつV-LOG PAINT SW : OFF時は制御不可 (ER2応答) とし、問い合わせにはOFFで応答する。
	LINEAR MATRIX	OSL:6C	V-LOG : ONかつV-LOG PAINT SW : OFF時は制御不可 (ER2応答) とし、問い合わせにはOFFで応答する。
	COLOR CORRECT	OSA:85	V-LOG : ONかつV-LOG PAINT SW : OFF時は制御不可 (ER2応答) とし、問い合わせにはOFFで応答する。
LENS			
	FOCUS MODE	OAF #D1	OAF/#D1は同義。更新通知は両方出る。
	AF SENSITIVITY	OSJ:D8	・ FOCUS MODEが“MANUAL”の時は制御不可 (ER2応答)
	ZOOM MODE	OSE:70 OSD:B3	・ PRESET PTZ SYNC MODEがONの時は制御不可 (ER2応答)
	MAX DIGITAL ZOOM	OSE:7A	・ ZOOM MODEが“i. ZOOM”または“Opt. ZOOM”の時は制御不可 (ER2応答)
	DIGITAL EXTENDER	OSJ:4E	・ ZOOM MODEが“i. Zoom”または“D. ZOOM”の時は制御不可 (ER2応答) とし、問い合わせにはOFFで応答する。
	O. I. S.	OSL:8B	
	O. I. S. MODE	OSL:8C OIS	
	ND FILTER	OFT	・ DAY/NIGHT:NIGHTの時は制御不可 (ER2応答)
MONITOR DISPLAY			
	WFM/VECT		
	MODE	OSL:8D	SFP+ MODEが「ST2110 JPEG XS」の時は制御不可 (ER2応答)
	POSITION	OSL:8E	
	STATUS INDICATOR		
	RETURN SELECT	OSL:B3	
	STATUS(AUTO)	OSA:88	
	LEVEL GAUGE	OSL:03 OSL:AF	
TRACKING DATA OUTPUT			
	SERIAL	OSJ:54	Formatが1080/119.88pまたは1080/100pの時は制御不可 (ER2応答) とし、問い合わせにはOFFで応答する。
	IP	OSJ:55	Formatが1080/119.88pまたは1080/100pの時は制御不可 (ER2応答) とし、問い合わせにはOFFで応答する。
	INVERT PAN/TILT AXIS	OSJ:C1	
	CAMERA ID	OSJ:F4	
CROP			
	UHD CROP	OSJ:2E	・ FORMATが2160/59.94p、2160/50pの時には、3値 (OFF、CROP(1080)、CROP(720)) が選択可能 ・ FORMATが2160/29.97p、2160/25p、2160/24p、2160/23.98pの時には、2値 (OFF、CROP(1080)) のみが選択可能 ・ 上記以外は制御不可 (ER2応答) とし、問い合わせにはOFFで応答する。
	CROP ZOOM	OSJ:92	UHD CROPがOFFの時は制御不可 (ER2応答)
	CROP AF	OSJ:91	UHD CROPがOFFの時は制御不可 (ER2応答)
	3G SDI1 OUT	OSI:32	UHD CROPがOFFの時は制御不可 (ER2応答)
	NDI OUT	OSJ:93	UHD CROPがOFFの時は制御不可 (ER2応答)
	IP(H. 264/H. 265) OUT1	OSI:33	UHD CROPがOFFの時は制御不可 (ER2応答)
	IP(H. 264/H. 265) OUT2	OSJ:94	UHD CROPがOFFの時は制御不可 (ER2応答)
	CROP MARKER	OSI:1A	UHD CROPがOFFの時は制御不可 (ER2応答)
	CROP OUT	OSI:16	UHD CROPがOFFの時は制御不可 (ER2応答)
	CROP ADJUST	OSI:17	UHD CROPがOFFの時は制御不可 (ER2応答)
	CROP H POSITION	OSJ:AF OSJ:2F OSJ:31 OSJ:33	UHD CROPがOFFの時は制御不可 (ER2応答)
	CROP V POSITION	OSJ:B0 OSJ:30 OSJ:32 OSJ:34	UHD CROPがOFFの時は制御不可 (ER2応答)
	CROP ZOOM RATIO	OSJ:B1 OSJ:98 OSJ:99 OSJ:9A OSJ:9B	・ UHD CROPがOFFの時は制御不可 (ER2応答) ・ CROP ZOOMがOFFの時は制御不可 (ER2応答)
PAN/TILT			
	INSTALL POSITION	#INS	
	SMART PICTURE FLIP	#SPF	
	FLIP DETECT ANGLE	#FDA QFS	
	P/T SPEED MODE	OSJ:2D	

メニュー		コマンド	備考
P/T ACCELERATION SETTING			
	P/T ACCELERATION	OSJ:A2	
	RISE S-CURVE	OSJ:A3	P/T ACCELERATIONがAUTOの時は制御不可 (ER2応答)
	FALL S-CURVE	OSJ:A4	P/T ACCELERATIONがAUTOの時は制御不可 (ER2応答)
	RISE ACCELERATION	OSJ:A5	P/T ACCELERATIONがAUTOの時は制御不可 (ER2応答)
	FALL ACCELERATION	OSJ:A6	P/T ACCELERATIONがAUTOの時は制御不可 (ER2応答)
SPEED WITH ZOOM POSITION		#SWZ	
FOCUS ADJUST WITH PTZ.		OAZ	FOCUS MODEがAUTOの時は制御不可 (ER2応答) とし、問い合わせにはOFFで応答する。
PRIVACY MODE		OSJ:A7	
POWER ON POSITION		OSJ:45	
PRESET NUMBER		OSJ:46	
PRESET			
PRESET PTZ SYNC MODE		OSL:CE	
PRESET SPEED UNIT		OSJ:29	
PRESET SPEED TABLE		#PST	
PRESET SPEED		#UPVS	
PRESET ACCELERATION SETTING			
PRESET ACCELERATION		OSJ:A8	
RISE S-CURVE		OSJ:A9	・ PRESET ACCELERATIONがAUTOの時は制御不可 (ER2応答) ・ PRESET PTZ SYNC MODEがONの時は制御不可 (ER2応答)
FALL S-CURVE		OSJ:AA	・ PRESET ACCELERATIONがAUTOの時は制御不可 (ER2応答) ・ PRESET PTZ SYNC MODEがONの時は制御不可 (ER2応答)
RISE ACCELERATION		OSJ:AB	・ PRESET ACCELERATIONがAUTOの時は制御不可 (ER2応答) ・ PRESET SPEED UNITがTIMEの時は制御不可 (ER2応答)
FALL ACCELERATION		OSJ:AC	・ PRESET ACCELERATIONがAUTOの時は制御不可 (ER2応答) ・ PRESET SPEED UNITがTIMEの時は制御不可 (ER2応答) ・ PRESET PTZ SYNC MODEがONの時は制御不可 (ER2応答)
RISE RAMP TIME		OSJ:AD	・ PRESET ACCELERATIONがAUTOの時は制御不可 (ER2応答) ・ PRESET SPEED UNITがSPEED TABLEの時は制御不可 (ER2応答)
FALL RAMP TIME		OSJ:AE	・ PRESET ACCELERATIONがAUTOの時は制御不可 (ER2応答) ・ PRESET SPEED UNITがSPEED TABLEの時は制御不可 (ER2応答)
PRESET SCOPE		OSE:71	
PRESET DIGITAL EXTENDER		OSE:7C	PRESET PTZ SYNC MODEがONの時は制御不可 (ER2応答)
PRESET CROP		OSJ:2A	UHD CROPがOFFの時は制御不可 (ER2応答) とし、問い合わせにはOFFで応答する。
PRESET THUMBNAIL UPDATE		OSJ:2B	
PRESET NAME		OSJ:2C	
PRESET IRIS		OSJ:5B	PRESET SCOPEがMODE Cの時は制御不可 (ER2応答) とし、問い合わせにはOFFで応答する。
PRESET SHUTTER		OSJ:D5	PRESET SCOPEがMODE BまたはMODE Cの時は制御不可 (ER2応答) とし、問い合わせにはOFFで応答する。
PRESET ZOOM MODE		OSE:7D	
FREEZE DURING PRESET		#PRF	
FILES			
SCENE FILE			
	MODE		
	FILE NO		
	FILE NAME		
	LIST		
	EXECUTE	OSL:8F XSF OSL:90 OSL:91	
USER FILE			
	MODE		
	FILE NO		
	FILE NAME		
	LIST		
	EXECUTE	OSL:92 OSL:93 OSL:94	
MAINTENANCE			
FAN SETTING			
	FAN1	#FAN #FS1	
	FAN2	#FA2 #FS2	
DATE/TIME			
	PRESENT	-	
	DATE YY	-	
	DATE MM	-	
	DATE DD	-	

メニュー		コマンド	備考
	TIME HH	-	
	TIME MM	-	
	TIME SS	-	
	SET EXECUTE	-	
	RESET	-	
	INITIALIZE		
	MENU INITIALIZE	-	
	ALL DATA INITIALIZE	-	
	VERSION		
	SYSTEM VERSION	QSL:99 QSV	QSVは60秒に一回 更新通知を出す
	HOUR METER		
	OPERATION	-	
	FAN1	-	
	FAN2	-	
	HDMI STATUS		
	CONNECT	-	
	FORMAT	-	
	VIDEO SAMPLING	-	
	MONITOR	-	
	ERROR STATUS	QER OSL:46	
	LENS		
	PAN/TILT		
	FAN1		
	FAN2		
	TEMPERATURE		
	WHITE SHADING		
	CORRECT	OSL:9B	
	W H SAW R	OSL:9C	
	W H SAW G	OSL:9D	
	W H SAW B	OSL:9E	
	W H PARA R	OSL:9F	
	W H PARA G	OSL:A0	
	W H PARA B	OSL:A1	
	W V SAW R	OSL:A2	
	W V SAW G	OSL:A3	
	W V SAW B	OSL:A4	
	W V PARA R	OSL:A5	
	W V PARA G	OSL:A6	
	W V PARA B	OSL:A7	
	WIRELESS CONTROL		
	WIRELESS CONTROL	#WLC	
	WIRELESS ID	#RID	
	STATUS LAMP		
	STATUS LAMP	#LMP	

メニューに紐づかないコマンド

コマンド名		コマンド	備考
LENS			
	ZOOM SCALE	QSJ:3D	
	DIGITAL ZOOM MAGNIFICATION	OSE:76	
	ZOOM SPEED CONTROL	#Z	
	ZOOM POSITION CONTROL	#AXZ	
	FOCUS SPEED CONTROL	#F	
	FOCUS POSITION CONTROL	#AXF	
	PUSH AUTO FOCUS	OSE:69	
	TOUCH AF	OSJ:28	
	IRIS CONTROL	#AXI	
	IRIS CONTROL	#I	
	IRIS CONTROL	ORV	
	IRIS FOLLOW	QSD:4F	
	LENS POSITION INFORMATION	#LPI	
	LENS POSITION INFORMATION CONTROL	#LPC	
	REQUEST IRIS F NO.	QIF	
	REQUEST ZOOM POSITION	#GZ	
	REQUEST FOCUS POSITION	#GF	
	REQUEST IRIS POSITION	#GI	
	FOCUS GUIDE	OSL:C3	FOCUS MODEがAUTOの時、UHD CROPがOFFでない時は制御不可 (ER2応答) とし、問い合わせにはOFFで応答する。
	FOCUS GUIDE POSITION	OSL:C4	
	FOCUS GUIDE STATUS(WEB UI)	OSL:C5	
	FOCUS GUIDE STATUS(DETAIL)	OSL:C6	
PAINT			
	REQUEST MATRIX(R/G/B/CY/MG/YE)	QSL:B2	
CROP			
	CROP ZOOM RATIO SPEED CONTROL	OSJ:9C	UHD CROPがOFFの時は制御不可 (ER2応答)
	CROP ZOOM RATIO SPEED CONTROL(YL)	OSJ:9D	UHD CROPがOFFの時は制御不可 (ER2応答)
	CROP ZOOM RATIO SPEED CONTROL(G)	OSJ:9E	UHD CROPがOFFの時は制御不可 (ER2応答)
	CROP ZOOM RATIO SPEED CONTROL(MG)	OSJ:9F	UHD CROPがOFFの時は制御不可 (ER2応答)
	CROP ZOOM RATIO SPEED CONTROL(YL,G,MG)	OSJ:A1	UHD CROPがOFFの時は制御不可 (ER2応答)
	GET CROP H/V POSITION (YL,G,MG)	OSJ:60	UHD CROPがOFFの時は制御不可 (ER2応答)
	CROP H/V POSITION SPEED CONTROL	OSJ:15	UHD CROPがOFFの時は制御不可 (ER2応答)
	CROP H/V POSITION SPEED CONTROL(YL)	OSJ:5D	UHD CROPがOFFの時は制御不可 (ER2応答)
	CROP H/V POSITION SPEED CONTROL(G)	OSJ:5E	UHD CROPがOFFの時は制御不可 (ER2応答)
	CROP H/V POSITION SPEED CONTROL(MG)	OSJ:5F	UHD CROPがOFFの時は制御不可 (ER2応答)
	CROP H/V POSITION SPEED CONTROL(YL/G/MG)	OSJ:A0	UHD CROPがOFFの時は制御不可 (ER2応答)
	CROP POSITION/ZOOM SPEED CONTROL (YL/G/MG)	OSJ:C2	UHD CROPがOFFの時は制御不可 (ER2応答)
	REQUEST CROP POSITION / CROP ZOOM POSITION	QSJ:C3	
PAN/TILT			
	PAN SPEED CONTROL	#P	
	TILT SPEED CONTROL	#T	
	P/T SPEED CONTROL	#PTS	
	P/T ABSOLUTE POSITION CONTROL	#APC	
	P/T RELATIVE POSITION CONTROL	#RPC	
	P/T ABSOLUTE POSITION CONTROL WITH SPEED	#APS	
	P/T RELATIVE POSITION CONTROL WITH SPEED	#RPS	
	LIMITATION CONTROL	#LC	
	LIMITATION CONTROL(TOGGLE)	#L	
CONVINIENT			
	GET GAIN/COLOR TEMPERATURE/SHUTTER/ND	#PTG	
	GETPAN/TILT/ZOOM/FOCUS/IRIS	#PTV	
	GETPAN/TILT/ZOOM/FOCUS/IRIS	#PTD	
PRESET			
	RECALL PRESET MEMORY	#R	
	SAVE PRESET MEMORY	#M	
	DELETE PRESET MEMORY	#C	
	PRESET ENTRYCONFIRMATION	#PE	
	REQUEST LATEST RECALL PRESET NO.	#S	
	PRESET COMPLETION NOTIFICATION	a	
	SAVE PRESET NAME	OSJ:35	
	DELETE PRESET NAME(SINGLE)	OSJ:36	
	DELETE PRESET NAME(ALL)	OSJ:37	
	UPDATE PRESET THUMBNAIL	OSJ:39	
	DELETE PRESET THUMBNAIL(SINGLE)	OSJ:3A	
	DELETE PRESET THUMBNAIL(ALL)	OSJ:3B	
	PRESET NAME/PRESET THUMBNAIL COUNTER	QSJ:3C	
OSD			
	MENU ON/OFF	DUS	
	MENU CANCEL	DPG	
	MENU ENTER	DIT	
	MENU UP(DIAL)	DUP	
	MENU DOWN(DIAL)	DDW	
	MENU UP	CUP	
	MENU DOWN	CDW	
	MENU RIGHT	CRT	
	MENU LEFT	CLT	
RP			
	OPERATION LOCK	OSJ:3E	
	RELEASE OPERATION LOCK	OSJ:3F	
	OPERATION LOCK STATUS	QSJ:40	
OTHER			
	MODEL NUMBER	QID	
	CAMERA NUMBER	OSL:AE	
	POWER ON / STANDBY	#O	
	RESOLUTION CONTROL	#RZL	
	CAMERA TITLE	OSJ:5C	

9. コマンド仕様一覧
BASIC CONFIG

コマンド名	種別	コマンド	Data値	設定値	コマンドタイプ	更新通知	camdata.html	使用例・備考
FREQUENCY	制御	OSE:77:[Data]	0	59.94Hz	cam	OSE:77:[Data]	OSE:77:[Data]	http://192.168.0.10/cgi-bin/aw_cam?cmd=OSE:77:1&res=1 実行後に再起動がかかる
	応答	OSE:77:[Data]	1	50.00Hz				
	要求	QSE:77	2	24.00Hz				
	応答	OSE:77:[Data]	3	23.98Hz				
FORMAT	制御	OSA:87:[Data]	01h	720/59.94p	cam	OSA:87:[Data]	OSA:87:0x[Data]	http://192.168.0.10/cgi-bin/aw_cam?cmd=OSA:87:01&res=1 [60Hz] 2160/60p, 1080/60p [59.94Hz] 2160/59.94p, 2160/29.97p, 1080/119.88p, 1080/59.94p, 1080/29.97p, 720/59.94p [50Hz] 2160/50p, 2160/25p, 1080/100p, 1080/50p, 1080/25p, 720/50p [24.00Hz]. 2160/24p, 1080/24p [23.98Hz] 2160/23.98p, 1080/23.98p
	応答	OSA:87:[Data]	02h	720/50p				
	要求	QSA:87	10h	1080/59.94p				
			11h	1080/50p				
			14h	1080/29.97p				
			15h	1080/25p				
			17h	2160/29.97p				
			18h	2160/25p				
			19h	2160/59.94p				
			1Ah	2160/50p				
	応答	OSA:87:[Data]	1Bh	2160/23.98p				
			1Fh	2160/60p				
20h			1080/60p					
21h			2160/24p					
22h	1080/24p							
23h	1080/23.98p							
26h	1080/119.88p							
27h	1080/100p							
SFP+ MODE	制御	OSL:00:[Data]	0	12G OUTPUT	cam	OSL:00:[Data]	-	http://192.168.0.10/cgi-bin/aw_cam?cmd=OSL:00:1&res=1
	応答	OSL:00:[Data]	1	ST2110/NW IF				
	要求	QSL:00	2	ST2110 JPEG XS				
	応答	OSL:00:[Data]						
V-LOG	制御	OSJ:56:[Data]	0	OFF	cam	OSJ:56:[Data]	OSJ:56:[Data]	http://192.168.0.10/cgi-bin/aw_cam?cmd=OSJ:56:0&res=1
	応答	OSJ:56:[Data]	1	ON				
	要求	QSI:56						
	応答	OSJ:56:[Data]						
V-LOG PAINT SW	制御	OSL:01:[Data]	0	OFF	cam	OSL:01:[Data]	OSL:01:[Data]	http://192.168.0.10/cgi-bin/aw_cam?cmd=OSL:01:1&res=1
	応答	OSL:01:[Data]	1	ON				
	要求	QSL:01						
	応答	OSL:01:[Data]						
HDR	制御	OSI:2C:[Data]	0	OFF	cam	OSI:2C:[Data]	OSI:2C:[Data]	http://192.168.0.10/cgi-bin/aw_cam?cmd=OSI:2C:1&res=1
	応答	OSI:2C:[Data]	1	ON				
	要求	QSI:2C						
	応答	OSI:2C:[Data]						
GAMUT	制御	OSL:02:[Data]	0	NORMAL	cam	OSL:02:[Data]	OSL:02:[Data]	http://192.168.0.10/cgi-bin/aw_cam?cmd=OSL:02:1&res=1
	応答	OSL:02:[Data]	1	WIDE_G2				
	要求	QSL:02						
	応答	OSL:02:[Data]						
SHOOTING MODE	制御	OSI:30:[Data]	0	NORMAL	cam	OSI:30:[Data]	OSI:30:[Data]	http://192.168.0.10/cgi-bin/aw_cam?cmd=OSI:30:0&res=1
	応答	OSI:30:[Data]	1	LOW LIGHT				
	要求	QSI:30						
	応答	OSI:30:[Data]						
SERIAL BAUD RATE	制御	OVP:04:[Data]	0	9600bps	cam	OVP:04:[Data]	-	http://192.168.0.10/cgi-bin/aw_cam?cmd=OVP:04:1&res=1
	応答	OVP:04:[Data]	1	38400bps				
	要求	QVP:04	2	115200bps				
	応答	OVP:04:[Data]						
BAR	制御	DCB:[Data]	0	OFF	cam	DCB:[Data]	OBR:[Data]	http://192.168.0.10/cgi-bin/aw_cam?cmd=DCB:1&res=1
	応答	DCB:[Data]	1	ON				
	要求	QBR						
	応答	OBR:[Data]						

コマンド名	種別	コマンド	Data値	設定値	コマンドタイプ	更新通知	camdata.html	使用例・備考	
COLOR BAR TYPE	制御	OSD:BA:[Data]	0	TYPE2:FULL TYPE1:SMPTE TYPE3:ARIB (MULT1) TYPE4:ARIB (UHD MULT1) TYPE5:ARIB (BT. 2020)	cam	OSD:BA:[Data]	-	http://192.168.0.10/cgi-bin/aw_cam?cmd=OSD:BA:0&res=1	
	応答	OSD:BA:[Data]	1						
	要求	QSD:BA	2						
	応答	OSD:BA:[Data]	3						
BAR TONE	制御	OSJ:27:[Data]	0	OFF ON	cam	OSJ:27:[Data]	-	http://192.168.0.10/cgi-bin/aw_cam?cmd=OSJ:27:0&res=1	
	応答	OSJ:27:[Data]							1
	要求	QSJ:27							
	応答	OSJ:27:[Data]							
TALLY	制御	#TAE[Data]	0	DISABLE ENABLE	ptz	tAE[Data]	tAE[Data]	http://192.168.0.10/cgi-bin/aw_ptz?cmd=%23TAE1&res=1	
	応答	tAE[Data]							1
	要求	#TAE							
	応答	tAE[Data]							
TALLY BRIGHTNESS	制御	OSA:D3:[Data]	0	LOW MID HIGH	cam	OSA:D3:[Data]	-	http://192.168.0.10/cgi-bin/aw_cam?cmd=OSA:D3:0&res=1	
	応答	OSA:D3:[Data]							1
	要求	QSA:D3							2
	応答	OSA:D3:[Data]							
R-Tally Control	制御	TLR:[Data]	0	OFF ON	cam	TLR:[Data]	TLR:[Data]	http://192.168.0.10/cgi-bin/aw_cam?cmd=TLR:1&res=1	
	応答	TLR:[Data]							1
	要求	QLR							
	応答	OLR:[Data]							
R-Tally Control	制御	#DA[Data]	0	OFF ON	ptz	dA[Data]	dA[Data]	http://192.168.0.10/cgi-bin/aw_ptz?cmd=%23DA1&res=1	
	応答	dA[Data]							1
	要求	#DA							
	応答	dA[Data]							
G-Tally Control	制御	TLG:[Data]	0	OFF ON	cam	TLG:[Data]	TLG:[Data]	http://192.168.0.10/cgi-bin/aw_cam?cmd=TLG:1&res=1	
	応答	TLG:[Data]							1
	要求	QLG							
	応答	OLG:[Data]							
Y-Tally Control	制御	TLY:[Data]	0	OFF ON	cam	TLY:[Data]	TLY:[Data]	http://192.168.0.10/cgi-bin/aw_cam?cmd=TLY:1&res=1	
	応答	TLY:[Data]							1
	要求	QLY							
	応答	OLY:[Data]							
TALLY INFORMATION	制御	-	[Data1] 0 1	[Data1] R-TALLY OFF R-TALLY ON	ptz	tAA[Data1][Data2] [Data3][Data4] [Data5][Data6][Data7] [Data8][Data9]	tAA[Data1][Data2] [Data3][Data4] [Data5][Data6][Data7] [Data8][Data9]	http://192.168.0.10/cgi-bin/aw_ptz?cmd=%23TAA&res=1	
	応答	-	[Data2] 0 1	[Data2] WIRED R-TALLY IN OFF WIRED R-TALLY IN ON					
	要求	#TAA	[Data3] 0 1	[Data3] COMMAND R-TALLY IN OFF COMMAND R-TALLY IN ON					
	応答	tAA[Data1][Data2][Data3] [Data4][Data5][Data6] [Data7][Data8][Data9]	[Data4] 0 1	[Data4] G-TALLY OFF G-TALLY ON					
			[Data5] 0 1	[Data5] RESERVE (WIRED G) COMMAND G-TALLY IN OFF COMMAND G-TALLY IN ON					
			[Data6] 0 1	[Data6] Y-TALLY OFF Y-TALLY ON					
			[Data7] 0 1	[Data7] RESERVE (WIRED Y) COMMAND Y-TALLY IN OFF COMMAND Y-TALLY IN ON					
			[Data8] 0 1	[Data8]					
			[Data9] 0 1	[Data9]					

コマンド名	種別	コマンド	Data値	設定値	コマンドタイプ	更新通知	camdata.html	使用例・備考
TALLY GUARD	制御	OSL:04:[Data]	0 1	OFF ON	cam	OSL:04:[Data]	OSL:04:[Data]	http://192.168.0.10/cgi-bin/aw_cam?cmd=OSL:04:1&res=1
	応答	OSL:04:[Data]						
	要求	QSL:04						
	応答	OSL:04:[Data]						
TALLY LED LIMIT R	制御	OSJ:D9:[Data]	0 1	UNLIMITED LIMITED	cam	OSJ:D9:[Data]	OSJ:D9:[Data]	http://192.168.0.10/cgi-bin/aw_cam?cmd=OSJ:D9:0&res=1
	応答	OSJ:D9:[Data]						
	要求	QSJ:D9						
	応答	OSJ:D9:[Data]						
TALLY LED LIMIT G	制御	OSJ:DA:[Data]	0 1	UNLIMITED LIMITED	cam	OSJ:DA:[Data]	OSJ:DA:[Data]	http://192.168.0.10/cgi-bin/aw_cam?cmd=OSJ:DA:0&res=1
	応答	OSJ:DA:[Data]						
	要求	QSJ:DA						
	応答	OSJ:DA:[Data]						
TALLY LED LIMIT Y	制御	OSL:05:[Data]	0 1	UNLIMITED LIMITED	cam	OSL:05:[Data]	OSL:05:[Data]	http://192.168.0.10/cgi-bin/aw_cam?cmd=OSL:05:1&res=1
	応答	OSL:05:[Data]						
	要求	QSL:05						
	応答	OSL:05:[Data]						
EXTERNAL OUTPUT1	制御	OSJ:41:[Data]	0 1 2 3	OFF R-TALLY G-TALLY Y-TALLY	cam	OSJ:41:[Data]	-	http://192.168.0.10/cgi-bin/aw_cam?cmd=OSJ:41:0&res=1
	応答	OSJ:41:[Data]						
	要求	QSJ:41						
	応答	OSJ:41:[Data]						
EXTERNAL OUTPUT2	制御	OSJ:42:[Data]	0 1 2 3	OFF R-TALLY G-TALLY Y-TALLY	cam	OSJ:42:[Data]	-	http://192.168.0.10/cgi-bin/aw_cam?cmd=OSJ:42:0&res=1
	応答	OSJ:42:[Data]						
	要求	QSJ:42						
	応答	OSJ:42:[Data]						
SYNC REF SIGNAL	制御	OSL:08:[Data]	0 1	BBS/TRI-LEVEL SYNC PTP	cam	OSL:08:[Data]	OSL:08:[Data]	http://192.168.0.10/cgi-bin/aw_cam?cmd=OSL:08:1&res=1
	応答	OSL:08:[Data]						
	要求	QSL:08						
	応答	OSL:08:[Data]						
SYNC GEN-LOCK H PHASE-COARSE	制御	OSL:09:[Data]	7Bh - 80h -	-5 - 0 -	cam	OSL:09:[Data]	OSL:09:0x[Data]	http://192.168.0.10/cgi-bin/aw_cam?cmd=OSL:09:85&res=1
	応答	OSL:09:[Data]						
	要求	QSL:09						
	応答	OSL:09:[Data]						
SYNC GEN-LOCK H PHASE-FINE	制御	OSL:0A:[Data]	1Ch - 80h -	-100 - 0 -	cam	OSL:0A:[Data]	OSL:0A:0x[Data]	http://192.168.0.10/cgi-bin/aw_cam?cmd=OSL:0A:E4&res=1
	応答	OSL:0A:[Data]						
	要求	QSL:0A						
	応答	OSL:0A:[Data]						
SYNC STATUS (GEN-LOCK / PTP)	制御	-	0 1	NO SYNC SYNC	cam	-	-	http://192.168.0.10/cgi-bin/aw_cam?cmd=QSL:C7&res=1
	応答	-						
	要求	QSL:C7						
	応答	OSL:C7:[Data]						
BAR ID	制御	OSD:BE:[Data]	0 1	OFF ON	cam	OSD:BE:[Data]	OSD:BE:[Data]	http://192.168.0.10/cgi-bin/aw_cam?cmd=OSD:BE:1&res=1
	応答	OSD:BE:[Data]						
	要求	QSD:BE						
	応答	OSD:BE:[Data]						
BAR ID BRIGHTNESS	制御	OSL:0B:[Data]	00h - 64h	0% - 100%	cam	OSL:0B:[Data]	OSL:0B:0x[Data]	http://192.168.0.10/cgi-bin/aw_cam?cmd=OSL:0B:64&res=1
	応答	OSL:0B:[Data]						
	要求	QSL:0B						
	応答	OSL:0B:[Data]						
BAR ID ID1 POSITION V	制御	OSL:0C:[Data]	0 - 5	0 - 5	cam	OSL:0C:[Data]	OSL:0C:[Data]	http://192.168.0.10/cgi-bin/aw_cam?cmd=OSL:0C:1&res=1
	応答	OSL:0C:[Data]						
	要求	QSL:0C						
	応答	OSL:0C:[Data]						
BAR ID ID1 POSITION H	制御	OSL:0D:[Data]	0h - Fh	0h - Fh	cam	OSL:0D:[Data]	OSL:0D:0x[Data]	http://192.168.0.10/cgi-bin/aw_cam?cmd=OSL:0D:1&res=1
	応答	OSL:0D:[Data]						
	要求	QSL:0D						
	応答	OSL:0D:[Data]						

コマンド名	種別	コマンド	Data値	設定値	コマンドタイプ	更新通知	camdata.html	使用例・備考
BAR ID ID1	制御	OSL:0E:[Data]	xxxxxxx (32 DATA in ASCII CODE)	BAR ID (FIXED 16 CHARACTORS)	cam	OSL:0E:[Data]	OSL:0E:[Data]	http://192.168.0.10/cgi-bin/aw_cam?cmd=OSL:0E:42415249443100000000000000000000&res=1 半角英数字 空白 ! # % & ' () * + , - . / : ; < = > ? [] _ ~
	応答	OSL:0E:[Data]						
	要求	QSL:0E						
	応答	OSL:0E:[Data]						
BAR ID ID2 POSITION V	制御	OSL:0F:[Data]	0	0	cam	OSL:0F:[Data]	OSL:0F:[Data]	http://192.168.0.10/cgi-bin/aw_cam?cmd=OSL:0F:1&res=1
	応答	OSL:0F:[Data]	-	-				
	要求	QSL:0F	5	5				
	応答	OSL:0F:[Data]						
BAR ID ID2 POSITION H	制御	OSL:10:[Data]	0h	0h	cam	OSL:10:[Data]	OSL:10:0x[Data]	http://192.168.0.10/cgi-bin/aw_cam?cmd=OSL:10:1&res=1
	応答	OSL:10:[Data]	-	-				
	要求	QSL:10	Fh	Fh				
	応答	OSL:10:[Data]						
BAR ID ID2	制御	OSL:11:[Data]	xxxxxxx (32 DATA in ASCII CODE)	BAR ID (FIXED 16 CHARACTORS)	cam	OSL:11:[Data]	OSL:11:[Data]	http://192.168.0.10/cgi-bin/aw_cam?cmd=OSL:11:42415249443200000000000000000000&res=1 半角英数字 空白 ! # % & ' () * + , - . / : ; < = > ? [] _ ~
	応答	OSL:11:[Data]						
	要求	QSL:11						
	応答	OSL:11:[Data]						
BAR ID OFFSET V	制御	OSL:12:[Data]	00h	0	cam	OSL:12:[Data]	OSL:12:0x[Data]	http://192.168.0.10/cgi-bin/aw_cam?cmd=OSL:12:01&res=1
	応答	OSL:12:[Data]	-	-				
	要求	QSL:12	59h	89				
	応答	OSL:12:[Data]						
BAR ID OFFSET H	制御	OSL:13:[Data]	00h	0	cam	OSL:13:[Data]	OSL:13:0x[Data]	http://192.168.0.10/cgi-bin/aw_cam?cmd=OSL:13:01&res=1
	応答	OSL:13:[Data]	-	-				
	要求	QSL:13	4Fh	79				
	応答	OSL:13:[Data]						

※コマンドタイプはptz : 回転台コマンド、cam : カメラコマンドを表します

OUTPUT

コマンド名	種別	コマンド	Data値	設定値	コマンドタイプ	更新通知	camdata.html	使用例・備考					
12G SDI OUT/SFP+ FORMAT SELECT	制御	OSJ:1E:[Data]	01h 02h 04h 05h 10h	720/59.94p 720/50p 1080/59.94i 1080/50i 1080/59.94p	cam	OSJ:1E:[Data]	-	http://192.168.0.10/cgi-bin/aw_cam?cmd=OSJ:1E:1&res=1 [60Hz] 2160/60p, 1080/60p [59.94Hz] 2160/59.94p, 2160/29.97p, 1080/59.94p, 1080/59.94i, 1080/29.97p, 720/59.94p [50Hz] 2160/50p, 2160/25p, 1080/50p, 1080/50i, 1080/25p, 720/50p [24.00Hz] 2160/24p, 1080/24p [23.98Hz] 2160/23.98p, 1080/23.98p					
	応答	OSJ:1E:[Data]	11h 14h 15h 17h	1080/50p 1080/29.97p 1080/25p 2160/29.97p									
	要求	QSJ:1E	18h 19h 1Ah 1Bh 1Fh	2160/25p 2160/59.94p 2160/50p 2160/23.98p 2160/60p									
	応答	OSJ:1E:[Data]	20h 21h 22h 23h	1080/60p 2160/24p 1080/24p 1080/23.98p									
	12G SDI OUT/SFP+ OUTPUT ITEM	制御	OSL:14:[Data]	0 1					MENU ONLY STATUS	cam	OSL:14:[Data]	-	http://192.168.0.10/cgi-bin/aw_cam?cmd=OSL:14:1&res=1
		応答	OSL:14:[Data]										
		要求	QSL:14										
		応答	OSL:14:[Data]										
	12G SDI OUT/SFP+ HDR OUTPUT SELECT	制御	OSJ:1F:[Data]	0 1 2					SDR (709) HDR (2020) HDR (709)	cam	OSJ:1F:[Data]	OSJ:1F:[Data]	http://192.168.0.10/cgi-bin/aw_cam?cmd=OSJ:1F:0&res=1
		応答	OSJ:1F:[Data]										
		要求	QSJ:1F										
		応答	OSJ:1F:[Data]										
	12G SDI OUT/SFP+ V-LOG OUTPUT SELECT	制御	OSJ:57:[Data]	0 1					V-LOG V709	cam	OSJ:57:[Data]	OSJ:57:[Data]	http://192.168.0.10/cgi-bin/aw_cam?cmd=OSJ:57:0&res=1
応答		OSJ:57:[Data]											
要求		QSJ:57											
応答		OSJ:57:[Data]											
12G SDI OUT/SFP+ 3G SDI	制御	OSJ:20:[Data]	0 1	LEVEL-A LEVEL-B	cam	OSJ:20:[Data]	OSJ:20:[Data]	http://192.168.0.10/cgi-bin/aw_cam?cmd=OSJ:20:0&res=1					
	応答	OSJ:20:[Data]											
	要求	QSJ:20											
	応答	OSJ:20:[Data]											
CHAR	制御	OSE:7B:[Data]	00h 01h 02h 10h 20h 40h	00h:OSD MIX OFF 01h:3G SDI1 ON 02h:HDMI ON 10h:IP/NDI HX ON 20h:12G SDI ON 40h:3G SDI2/PM ON	cam	OSE:7B:[Data]	OSE:7B:0x[Data]	http://192.168.0.10/cgi-bin/aw_cam?cmd=OSE:7B:B3&res=1 bit0:3G SDI bit1:HDMI bit2:reserve bit3:reserve bit4:IP/NDI HX bit5:12G SDI bit6:3G SDI2/PM bit7:NDI					
	応答	OSE:7B:[Data]											
	要求	QSE:7B											
	応答	OSE:7B:[Data]											
3G SDI OUT1 FORMAT SELECT	制御	OSJ:21:[Data]	01h 02h 04h 05h 10h 11h 14h 15h 20h 22h 23h	720/59.94p 720/50p 1080/59.94i 1080/50i 1080/59.94p 1080/50p 1080/29.97p 1080/25p 1080/60p 1080/24p 1080/23.98p	cam	OSJ:21:[Data]	-	http://192.168.0.10/cgi-bin/aw_cam?cmd=OSJ:21:1&res=1 [60Hz] 1080/60p [59.94Hz] 1080/59.94p, 1080/59.94i, 1080/29.97p, 720/59.94p [50Hz] 1080/50p, 1080/50i, 1080/25p, 720/50p [24.00Hz] 1080/24p [23.98Hz] 1080/23.98p					
	応答	OSJ:21:[Data]											
	要求	QSJ:21											
	応答	OSJ:21:[Data]											

コマンド名	種別	コマンド	Data値	設定値	コマンドタイプ	更新通知	camdata.html	使用例・備考
3G SDI OUT1 HDR OUTPUT SELECT	制御	OSJ:22:[Data]	0	SDR (709) HDR (2020) HDR (709)	cam	OSJ:22:[Data]	OSJ:22:[Data]	http://192.168.0.10/cgi-bin/aw_cam?cmd=OSJ:22:0&res=1
	応答	OSJ:22:[Data]	1					
	要求	QSJ:22	2					
	応答	OSJ:22:[Data]						
3G SDI OUT1 V-LOG OUTPUT SELECT	制御	OSJ:58:[Data]	0	V-LOG V709	cam	OSJ:58:[Data]	OSJ:58:[Data]	http://192.168.0.10/cgi-bin/aw_cam?cmd=OSJ:58:0&res=1
	応答	OSJ:58:[Data]	0					
	要求	QSJ:58	1					
	応答	OSJ:58:[Data]						
3G SDI OUT1 OUTPUT ITEM	制御	OSL:15:[Data]	0	MENU ONLY STATUS	cam	OSL:15:[Data]	-	http://192.168.0.10/cgi-bin/aw_cam?cmd=OSL:15:1&res=1
	応答	OSL:15:[Data]	0					
	要求	QSL:15	1					
	応答	OSL:15:[Data]						
3G SDI OUT1 3G SDI	制御	OSI:29:[Data]	0	LEVEL-A LEVEL-B	cam	OSI:29:[Data]	OSI:29:[Data]	http://192.168.0.10/cgi-bin/aw_cam?cmd=OSI:29:0&res=1
	応答	OSI:29:[Data]	0					
	要求	QSI:29	1					
	応答	OSI:29:[Data]						
3G SDI OUT2/PM OUTPUT SELECT	制御	OSL:17:[Data]	0	CAM RETURN	cam	OSL:17:[Data]	-	http://192.168.0.10/cgi-bin/aw_cam?cmd=OSL:17:1&res=1
	応答	OSL:17:[Data]	0					
	要求	QSL:17	1					
	応答	OSL:17:[Data]						
3G SDI OUT2/PM FORMAT SELECT	制御	OSJ:23:[Data]	01h	720/59.94p 720/50p 1080/59.94i 1080/50i 1080/59.94p 1080/50p 1080/29.97p 1080/25p 1080/60p 1080/24p 1080/23.98p	cam	OSJ:23:[Data]	-	http://192.168.0.10/cgi-bin/aw_cam?cmd=OSJ:23:1&res=1 [60Hz] 1080/60p [59.94Hz] 1080/59.94p, 1080/59.94i, 1080/29.97p, 720/59.94p [50Hz] 1080/50p, 1080/50i, 1080/25p, 720/50p [24.00Hz] 1080/24p [23.98Hz] 1080/23.98p
	応答	OSJ:23:[Data]	02h					
	要求	QSJ:23	04h					
	応答	OSJ:23:[Data]	05h					
3G SDI OUT2/PM HDR OUTPUT SELECT	制御	OSJ:24:[Data]	0	SDR (709) HDR (2020) HDR (709)	cam	OSJ:24:[Data]	OSJ:24:[Data]	http://192.168.0.10/cgi-bin/aw_cam?cmd=OSJ:24:0&res=1
	応答	OSJ:24:[Data]	1					
	要求	QSJ:24	2					
	応答	OSJ:24:[Data]						
3G SDI OUT2/PM V-LOG OUTPUT SELECT	制御	OSJ:59:[Data]	0	V-LOG V709	cam	OSJ:59:[Data]	OSJ:59:[Data]	http://192.168.0.10/cgi-bin/aw_cam?cmd=OSJ:59:0&res=1
	応答	OSJ:59:[Data]	0					
	要求	QSJ:59	1					
	応答	OSJ:59:[Data]						
3G SDI OUT2/PM OUTPUT ITEM	制御	OSL:18:[Data]	0	MENU ONLY STATUS	cam	OSL:18:[Data]	-	http://192.168.0.10/cgi-bin/aw_cam?cmd=OSL:18:1&res=1
	応答	OSL:18:[Data]	0					
	要求	QSL:18	1					
	応答	OSL:18:[Data]						
3G SDI OUT2/PM 3G SDI	制御	OSL:1A:[Data]	0	LEVEL-A LEVEL-B	cam	OSL:1A:[Data]	OSL:1A:[Data]	http://192.168.0.10/cgi-bin/aw_cam?cmd=OSL:1A:1&res=1
	応答	OSL:1A:[Data]	0					
	要求	QSL:1A	1					
	応答	OSL:1A:[Data]						

コマンド名	種別	コマンド	Data値	設定値	コマンドタイプ	更新通知	camdata.html	使用例・備考
HDMI FORMAT SELECT	制御	OSJ:25:[Data]	01h	720/59.94p	cam	OSJ:25:[Data]	-	http://192.168.0.10/cgi-bin/aw_cam?cmd=OSJ:25:1&res=1 [60Hz] 2160/60p, 1080/60p [59.94Hz] 2160/59.94p, 2160/29.97p, 1080/119.88p, 1080/59.94p, 1080/59.94i, 1080/29.97p, 720/59.94p [50Hz] 2160/50p, 2160/25p, 1080/100p, 1080/50p, 1080/50i, 1080/25p, 720/50p [24.00Hz] 2160/24p, 1080/24p [23.98Hz] 2160/23.98p, 1080/23.98p
			02h	720/50p				
			04h	1080/59.94i				
			05h	1080/50i				
	応答	OSJ:25:[Data]	10h	1080/59.94p				
			11h	1080/50p				
			14h	1080/29.97p				
			15h	1080/25p				
	要求	QSJ:25	17h	2160/29.97p				
			18h	2160/25p				
			19h	2160/59.94p				
			1Ah	2160/50p				
	応答	OSJ:25:[Data]	1Bh	2160/23.98p				
			1Fh	2160/60p				
			20h	1080/60p				
			21h	2160/24p				
		22h	1080/24p					
		23h	1080/23.98p					
		26h	1080/119.88p					
		27h	1080/100p					
HDMI HDR OUTPUT SELECT	制御	OSJ:26:[Data]	0	SDR (709)	cam	OSJ:26:[Data]	OSJ:26:[Data]	http://192.168.0.10/cgi-bin/aw_cam?cmd=OSJ:26:0&res=1
	応答	OSJ:26:[Data]	1	HDR (2020)				
	要求	QSJ:26	2	HDR (709)				
	応答	OSJ:26:[Data]						
HDMI V-LOG OUTPUT SELECT	制御	OSJ:5A:[Data]	0	V-LOG	cam	OSJ:5A:[Data]	OSJ:5A:[Data]	http://192.168.0.10/cgi-bin/aw_cam?cmd=OSJ:5A:0&res=1
	応答	OSJ:5A:[Data]	1	V709				
	要求	QSJ:5A						
	応答	OSJ:5A:[Data]						
HDMI VIDEO SAMPLING	制御	OSE:68:[Data]	2	4:2:2/10bit	cam	OSE:68:[Data]	-	http://192.168.0.10/cgi-bin/aw_cam?cmd=OSE:68:2&res=1
	応答	OSE:68:[Data]	4	4:2:0/8bit				
	要求	QSE:68						
	応答	OSE:68:[Data]						

RETURN

コマンド名	種別	コマンド	Data値	設定値	コマンドタイプ	更新通知	camdata.html	使用例・備考
RETURN ID	制御	OSL:1B:[Data]	xxxxxxx (10 DATA in ASCII CODE)	RETURN ID (FIXED 5 CHARACTORS)	cam	OSL:1B:[Data]	-	http://192.168.0.10/cgi-bin/aw_cam?cmd=OSL:1B:5245542F31&res=1 半角英数字 空白 ! # % & ' () * + , - . / : ; < = > ? [] _ ~
	応答	OSL:1B:[Data]						
	要求	OSL:1B						
	応答	OSL:1B:[Data]						

AUDIO

コマンド名	種別	コマンド	Data値	設定値	コマンドタイプ	更新通知	camdata.html	使用例・備考
AUDIO	制御	OSA:D0:[Data]			cam	OSA:D0:[Data]	OSA:D0:[Data]	http://192.168.0.10/cgi-bin/aw_cam?cmd=OSA:D0:1&res=1
	応答	OSA:D0:[Data]	0	OFF				
	要求	QSA:D0	1	ON				
	応答	OSA:D0:[Data]						
AUDIO INPUT SETTING INPUT SELECT	制御	OSL:1C:[Data1]:[Data2]	[Data1]	[Data1]	cam	OSL:1C:[Data1]:[Data2]	OSL:1C:0:[Data2] OSL:1C:1:[Data2]	http://192.168.0.10/cgi-bin/aw_cam?cmd=OSL:1C:1:2&res=1
	応答	OSL:1C:[Data1]:[Data2]	0	INPUT1				
	要求	QSL:1C:[Data1]	1	INPUT2				
	応答	OSL:1C:[Data1]:[Data2]	[Data2]	[Data2] LINE MIC MIC+48V				
AUDIO INPUT SETTING MIC GAIN	制御	OSL:1D:[Data1]:[Data2]	[Data1]	[Data1]	cam	OSL:1D:[Data1]:[Data2]	OSL:1D:0:[Data2] OSL:1D:1:[Data2]	http://192.168.0.10/cgi-bin/aw_cam?cmd=OSL:1D:0:1&res=1
	応答	OSL:1D:[Data1]:[Data2]	0	INPUT1				
	要求	QSL:1D:[Data1]	1	INPUT2				
	応答	OSL:1D:[Data1]:[Data2]	[Data2]	[Data2] 60dB 40dB				
AUDIO INPUT SETTING LINE LEVEL	制御	OSA:D4:[Data1]:[Data2]	[Data1]	[Data1]	cam	OSA:D4:[Data1]:[Data2]	OSA:D4:0:[Data2] OSA:D4:1:[Data2]	http://192.168.0.10/cgi-bin/aw_cam?cmd=OSA:D4:0:1&res=1
	応答	OSA:D4:[Data1]:[Data2]	0	INPUT1				
	要求	QSA:D4:[Data1]	1	INPUT2				
	応答	OSA:D4:[Data1]:[Data2]	[Data2]	[Data2] +4dB 0dB				
AUDIO OUTPUT SETTING CH SELECT	制御	OSL:1E:[Data]	0	INPUT1/INPUT2	cam	OSL:1E:[Data]	OSL:1E:[Data]	http://192.168.0.10/cgi-bin/aw_cam?cmd=OSL:1E:1&res=1
	応答	OSL:1E:[Data]	1	INPUT1				
	要求	QSL:1E	2	INPUT2				
	応答	OSL:1E:[Data]						
AUDIO OUTPUT SETTING VOLUME LEVEL	制御	OSA:D5:[Data1]:[Data2]	[Data1]	[Data1]	cam	OSA:D5:[Data1]:[Data2]	OSA:D5:0:[Data2] OSA:D5:1:[Data2]	http://192.168.0.10/cgi-bin/aw_cam?cmd=OSA:D5:0:50&res=1
	応答	OSA:D5:[Data1]:[Data2]	0	CH1				
	要求	QSA:D5:[Data1]	1	CH2				
	応答	OSA:D5:[Data1]:[Data2]	[Data2]	[Data2] -40dB - 80h - 94h				
AUDIO OUTPUT SETTING HEAD ROOM	制御	OSA:D6:[Data]	0	FS-12dB	cam	OSA:D6:[Data]	OSA:D6:[Data]	http://192.168.0.10/cgi-bin/aw_cam?cmd=OSA:D6:1&res=1
	応答	OSA:D6:[Data]	1	FS-18dB				
	要求	QSA:D6	2	FS-20dB				
	応答	OSA:D6:[Data]						

IP SIGNAL

コマンド名	種別	コマンド	Data値	設定値	コマンドタイプ	更新通知	camdata.html	使用例・備考
NDI FORMAT SELECT	制御	OSL:21:[Data]	01h	720/59.94p	cam	OSL:21:[Data]	-	http://192.168.0.10/cgi-bin/aw_cam?cmd=OSL:21:01&res=1 [60Hz] 2160/60p, 1080/60p [59.94Hz] 2160/59.94p, 2160/29.97p, 1080/59.94p, 1080/29.97p, 720/59.94p [50Hz] 2160/50p, 2160/25p, 1080/50p, 1080/25p, 720/50p [24.00Hz] 2160/24p, 1080/24p [23.98Hz] 2160/23.98p, 1080/23.98p
			02h	720/50p				
			10h	1080/59.94p				
			11h	1080/50p				
	応答	OSL:21:[Data]	14h	1080/29.97p				
			15h	1080/25p				
			17h	2160/29.97p				
			18h	2160/25p				
	要求	QSL:21	19h	2160/59.94p				
			1Ah	2160/50p				
			1Bh	2160/23.98p				
			1Fh	2160/60p				
応答	OSL:21:[Data]	20h	1080/60p					
		21h	2160/24p					
		22h	1080/24p					
		23h	1080/23.98p					
IP(H.264/H.265) OUTPUT ITEM	制御	OSL:23:[Data]	0	MENU ONLY STATUS	cam	OSL:23:[Data]	-	http://192.168.0.10/cgi-bin/aw_cam?cmd=OSL:23:1&res=1
	応答	OSL:23:[Data]						
	要求	QSL:23						
	応答	OSL:23:[Data]						
ST2110 MAIN VIDEO TX FORMAT	制御	OSL:AA:[Data]	01h	720/59.94p	cam	OSL:AA:[Data]	-	http://192.168.0.10/cgi-bin/aw_cam?cmd=OSL:AA:01&res=1
			02h	720/50p				
			04h	1080/59.94i				
			05h	1080/50i				
	応答	OSL:AA:[Data]	10h	1080/59.94p				
			11h	1080/50p				
			14h	1080/29.97p				
			15h	1080/25p				
	要求	QSL:AA	20h	1080/60p				
			22h	1080/24p				
			23h	1080/23.98p				
			FFh	DISABLE				
応答	OSL:AA:[Data]	01h	720/59.94p					
		02h	720/50p					
		04h	1080/59.94i					
		05h	1080/50i					
制御	-	-	10h	1080/59.94p	cam	OSL:AC:[Data]	-	http://192.168.0.10/cgi-bin/aw_cam?cmd=QSL:AC&res=1
			11h	1080/50p				
			14h	1080/29.97p				
			15h	1080/25p				
応答	-	-	20h	1080/60p				
			22h	1080/24p				
			23h	1080/23.98p				
			FFh	DISABLE				
要求	QSL:AC	-	01h	720/59.94p				
			02h	720/50p				
			04h	1080/59.94i				
			05h	1080/50i				
応答	OSL:AC:[Data]	-	10h	1080/59.94p				
			11h	1080/50p				
			14h	1080/29.97p				
			15h	1080/25p				
制御	-	-	20h	1080/60p				
			22h	1080/24p				
			23h	1080/23.98p				
			FFh	DISABLE				

コマンド名	種別	コマンド	Data値	設定値	コマンドタイプ	更新通知	camdata.html	使用例・備考
ST2110 MONITOR VIDEO TX FORMAT	制御	-	01h 02h 04h	720/59.94p 720/50p 1080/59.94i	cam	OSL:AD:[Data]	-	http://192.168.0.10/cgi-bin/aw_cam?cmd=OSL:AD&res=1
	応答	-	05h 10h 11h	1080/50i 1080/59.94p 1080/50p				
	要求	OSL:AD	14h 15h 20h	1080/29.97p 1080/25p 1080/60p				
	応答	OSL:AD:[Data]	22h 23h FFh	1080/24p 1080/23.98p DISABLE				
ST2110 RET VIDEO RX FORMAT	制御	OSL:B4:[Data]	04h 05h 10h	1080/59.94i 1080/50i 1080/59.94p	cam	OSL:B4:[Data]	-	http://192.168.0.10/cgi-bin/aw_cam?cmd=OSL:B4&res=1
	応答	OSL:B4:[Data]	11h 14h 15h	1080/50p 1080/29.97p 1080/25p				
	要求	OSL:B4	20h 22h 23h	1080/60p 1080/24p 1080/23.98p				
	応答	OSL:B4:[Data]	04h 05h 10h	1080/59.94i 1080/50i 1080/59.94p				
JPEG XS TX VIDEO SELECT	制御	OSL:C8:[Data]	0 1	MAIN CROP	cam	OSL:C8:[Data]	-	http://192.168.0.10/cgi-bin/aw_cam?cmd=OSL:C8:1&res=1
	応答	OSL:C8:[Data]						
	要求	OSL:C8						
	応答	OSL:C8:[Data]						

コマンド名	種別	コマンド	Data値	設定値	コマンドタイプ	更新通知	camdata.html	使用例・備考
MAIN VIDEO JPEG XS TX FORMAT	制御	OSL:C9:[Data]	10h	1080/59.94p	cam	OSL:C9:[Data]	-	http://192.168.0.10/cgi-bin/aw_cam?cmd=QSL:C9&res=1
			11h	1080/50p				
			14h	1080/29.97p				
			15h	1080/25p				
	応答	OSL:C9:[Data]	17h	2160/29.97p				
			18h	2160/25p				
			19h	2160/59.94p				
			1Ah	2160/50p				
要求	QSL:C9	1Bh	2160/23.98p					
		1Fh	2160/60p					
		20h	1080/60p					
		21h	2160/24p					
応答	OSL:C9:[Data]	22h	1080/24p					
		23h	1080/23.98p					
		FFh	DISABLE					
CROP VIDEO JPEG XS TX FORMAT	制御	OSL:CA:[Data]	10h	1080/59.94p	cam	OSL:CA:[Data]	-	http://192.168.0.10/cgi-bin/aw_cam?cmd=QSL:CA&res=1
			11h	1080/50p				
			14h	1080/29.97p				
			15h	1080/25p				
	応答	OSL:CA:[Data]	20h	1080/60p				
			22h	1080/24p				
			23h	1080/23.98p				
要求	QSL:CA	10h	1080/59.94p					
		11h	1080/50p					
		14h	1080/29.97p					
		15h	1080/25p					
応答	OSL:CA:[Data]	20h	1080/60p					
		22h	1080/24p					
		23h	1080/23.98p					
		FFh	DISABLE					

コマンド名	種別	コマンド	Data値	設定値	コマンドタイプ	更新通知	camdata.html	使用例・備考
RET VIDEO JPEG XS RX FORMAT	制御	OSL:CB:[Data]	04h	1080/59.94i	cam	OSL:CB:[Data]	-	http://192.168.0.10/cgi-bin/aw_cam?cmd=QSL:CB&res=1
			05h	1080/50i				
			10h	1080/59.94p				
			11h	1080/50p				
	応答	OSL:CB:[Data]	14h	1080/29.97p				
			15h	1080/25p				
			20h	1080/60p				
			22h	1080/24p				
要求	QSL:CB	23h	1080/23.98p					
		04h	1080/59.94i					
		05h	1080/50i					
		10h	1080/59.94p					
応答	OSL:CB:[Data]	11h	1080/50p					
		14h	1080/29.97p					
		15h	1080/25p					
		20h	1080/60p					
			22h	1080/24p				
			23h	1080/23.98p				
			FFh	DISABLE				

PAINT

コマンド名	種別	コマンド	Data値	設定値	コマンドタイプ	更新通知	camdata.html	使用例・備考
GAIN	制御	OSL:25:[Data]	02h	-6dB	cam	OSL:25:[Data]	OSL:25:0x[Data]	http://192.168.0.10/cgi-bin/aw_cam?cmd=OSL:25:0A&res=1
	応答	OSL:25:[Data]	-	-				
	要求	QSL:25	08h	0dB				
	応答	OSL:25:[Data]	14h	12dB				
AGC	制御	OSL:26:[Data]	0	OFF	cam	OSL:26:[Data]	OSL:26:[Data]	http://192.168.0.10/cgi-bin/aw_cam?cmd=OSL:26:1&res=1
	応答	OSL:26:[Data]	1	ON				
	要求	QSL:26						
	応答	OSL:26:[Data]						
GAIN	制御	OGU:[Data]	02h	-6dB	cam	OGU:[Data]	OGU:0x[Data]	http://192.168.0.10/cgi-bin/aw_cam?cmd=OGU:08&res=1
	応答	OGU:[Data]	08h	0dB				
	要求	QGU	14h	12dB				
	応答	OGU:[Data]	80h	AGC ON				
AGC MAX GAIN	制御	OSD:69:[Data]	01	6dB	cam	OSD:69:[Data]	OSD:69:[Data]	http://192.168.0.10/cgi-bin/aw_cam?cmd=OSD:69:01&res=1
	応答	OSD:69:[Data]	02	12dB				
	要求	QSD:69						
	応答	OSD:69:[Data]						
FRAME MIX SW	制御	OSL:27:[Data]	0	OFF	cam	OSL:27:[Data]	OSL:27:[Data]	http://192.168.0.10/cgi-bin/aw_cam?cmd=OSL:27:1&res=1
	応答	OSL:27:[Data]	1	ON				
	要求	QSL:27						
	応答	OSL:27:[Data]						
FRAME MIX	制御	OSL:28:[Data]	06h	+6dB	cam	OSL:28:[Data]	OSL:28:0x[Data]	http://192.168.0.10/cgi-bin/aw_cam?cmd=OSL:28:0C&res=1
	応答	OSL:28:[Data]	0Ch	+12dB				
	要求	QSL:28	12h	+18dB				
	応答	OSL:28:[Data]	18h	+24dB				
FRAME MIX	制御	OSA:65:[Data]	00h	OFF	cam	OSA:65:[Data]	OSA:65:0x[Data]	http://192.168.0.10/cgi-bin/aw_cam?cmd=OSA:65:00&res=1
	応答	OSA:65:[Data]	06h	+6dB				
	要求	QSA:65	12h	+18dB				
	応答	OSA:65:[Data]	18h	+24dB				
DAY/NIGHT	制御	#D6[Data]	0	OFF	ptz	d6[Data]	d6[Data]	http://192.168.0.10/cgi-bin/aw_ptz?cmd=%23D60&res=1
	応答	d6[Data]	1	ON				
	要求	#D6						
	応答	d6[Data]						
AUTO IRIS	制御	ORS:[Data]	0	OFF	cam	ORS:[Data]	ORS:[Data]	http://192.168.0.10/cgi-bin/aw_cam?cmd=ORS:1&res=1
	応答	ORS:[Data]	1	ON				
	要求	QRS						
	応答	ORS:[Data]						
AUTO IRIS	制御	#D3[Data]	0	OFF	ptz	d3[Data]	d3[Data]	http://192.168.0.10/cgi-bin/aw_ptz?cmd=%23D30&res=1
	応答	d3[Data]	1	ON				
	要求	#D3						
	応答	d3[Data]						
IRIS WINDOW SELECT	制御	OSJ:02:[Data]	1	1	cam	OSJ:02:[Data]	OSJ:02:[Data]	http://192.168.0.10/cgi-bin/aw_cam?cmd=OSJ:02:1&res=1
	応答	OSJ:02:[Data]	2	2				
	要求	QSJ:02	3	3				
	応答	OSJ:02:[Data]	4	4				
AUTO IRIS WINDOW	制御	OSL:CC:[Data]	0	OFF	cam	OSL:CC:[Data]	-	http://192.168.0.10/cgi-bin/aw_cam?cmd=OSL:CC:1&res=1
	応答	OSL:CC:[Data]	1	ON				
	要求	QSL:CC						
	応答	OSL:CC:[Data]						

コマンド名	種別	コマンド	Data値	設定値	コマンドタイプ	更新通知	camdata.html	使用例・備考
AUTO IRIS WINDOW POSITION	制御	OSL:CD:[Data1]:[Data2]:[Data3]:[Data4]	[Data1] 00h - 08h	[Data1]UPPER LEFT (H) 0 - 8	cam	a1]:[Data2]:[Dat	-	http://192.168.0.10/cgi-bin/aw_cam?cmd=OSL:CD:0:0:8:4&res=1
	応答	OSL:CD:[Data1]:[Data2]:[Data3]:[Data4]	[Data2] 00h - 04h	[Data2]UPPER LEFT (V) 0 - 4				
	要求	QSL:CD	[Data3] 00h - 08h	[Data3]BOTTOM RIGHT (H) 0 - 8				
	応答	OSL:CD:[Data1]:[Data2]:[Data3]:[Data4]	[Data4] 00h - 04h	[Data4]BOTTOM RIGHT (V) 0 - 4				
PICTURE LEVEL	制御	OSD:48:[Data]	00h	-50	cam	OSD:48:[Data]	OSD:48:0x[Data]	http://192.168.0.10/cgi-bin/aw_cam?cmd=OSD:48:32&res=1
	応答	OSD:48:[Data]	- 32h	- 0				
	要求	QSD:48	- 64h	- 50				
	応答	OSD:48:[Data]						
IRIS PEAK RATIO	制御	OSL:29:[Data]	00h	0	cam	OSL:29:[Data]	OSL:29:0x[Data]	http://192.168.0.10/cgi-bin/aw_cam?cmd=OSL:29:64&res=1
	応答	OSL:29:[Data]	-	-				
	要求	QSL:29	- 64h	- 100				
	応答	OSL:29:[Data]						
AUTO IRIS CLOSE LIMIT	制御	OSJ:C0:[Data]	0	NORMAL	cam	OSJ:C0:[Data]	OSJ:C0:[Data]	http://192.168.0.10/cgi-bin/aw_cam?cmd=OSJ:C0:0&res=1
	応答	OSJ:C0:[Data]	1	F8				
	要求	QSJ:C0	2	F7				
	応答	OSJ:C0:[Data]	3	F5.6				
IRIS SPEED	制御	OSJ:01:[Data]	0	1	cam	OSJ:01:[Data]	OSJ:01:[Data]	http://192.168.0.10/cgi-bin/aw_cam?cmd=OSJ:01:0&res=1
	応答	OSJ:01:[Data]	1	2				
	要求	QSJ:01	2	3				
	応答	OSJ:01:[Data]						
ATW	制御	OSL:2A:[Data]	0	OFF	cam	OSL:2A:[Data]	OSL:2A:[Data]	http://192.168.0.10/cgi-bin/aw_cam?cmd=OSL:2A:1&res=1
	応答	OSL:2A:[Data]	1	ON				
	要求	QSL:2A						
	応答	OSL:2A:[Data]						
WHITE BALANCE MODE	制御	OSL:2B:[Data]	0	AWB A	cam	OSL:2B:[Data]	OSL:2B:[Data]	http://192.168.0.10/cgi-bin/aw_cam?cmd=OSL:2B:1&res=1
	応答	OSL:2B:[Data]	1	AWB B				
	要求	QSL:2B	2	PRESET 3200K				
	応答	OSL:2B:[Data]	3 4	PRESET 5600K VAR				
WHITE BALANCE MODE	制御	OAW:[Data]	0	ATW	cam	OAW:[Data]	OAW:[Data]	http://192.168.0.10/cgi-bin/aw_cam?cmd=OAW:1&res=1
			1	AWC A				
			2	AWC B				
			3	---				
	応答	OAW:[Data]	4	PRESET 3200K				
			5	PRESET 5600K				
			9	VAR				
要求	QAW	0	ATW					
		1	---					
		2	AWC A					
		3	AWC B					
応答	OAW:[Data]	4	PRESET 3200K					
		5	PRESET 5600K					
		9	VAR					

コマンド名	種別	コマンド	Data値	設定値	コマンドタイプ	更新通知	camdata.html	使用例・備考
AWB	制御	OWS	-	-	cam	OWS ER3:OWS	-	http://192.168.0.10/cgi-bin/aw_cam?cmd=OWS&res=1 AWB実行時のシーケンスは6章参照
	応答	OWS						
	要求	-						
	応答	-						
ABB	制御	OAS	-	-	cam	OAS ER3:OAS	-	http://192.168.0.10/cgi-bin/aw_cam?cmd=OAS&res=1
	応答	OAS						
	要求	-						
	応答	-						
W. BAL VAR	制御	OSI:20:[Data1]:[Data2]	[Data1] 007D0h	[Data1] 2000K	cam	OSI:20:[Data1]:[Data2]	OSI:20:0x[Data1] :[Data2]	http://192.168.0.10/cgi-bin/aw_cam?cmd=OSI:20:007D0&res=1
	応答	OSI:20:[Data1]:[Data2]	-	-				
	要求	QSI:20	03A98h [Data2]	15000K [Data2]				
	応答	OSI:20:[Data1]:[Data2]	0h	VALID				
W. BAL VAR INC	制御	OSI:1E:[Data]	1h	1	cam	OSI:1E:[Data]	-	http://192.168.0.10/cgi-bin/aw_cam?cmd=OSI:1E:1&res=1 選択可能なW. BAL VARのうち[Data]段階だけ増加させる OSI:20の更新通知が送信される
	応答	OSI:1E:[Data]	-	-				
	要求	-	Ah	10				
	応答	-	-	-				
W. BAL VAR DEC	制御	OSI:1F:[Data]	1h	1	cam	OSI:1F:[Data]	-	http://192.168.0.10/cgi-bin/aw_cam?cmd=OSI:1F:1&res=1 選択可能なW. BAL VARのうち[Data]段階だけ減少させる OSI:20の更新通知が送信される
	応答	OSI:1F:[Data]	-	-				
	要求	-	Ah	10				
	応答	-	-	-				
ATW SPEED	制御	OSI:25:[Data]	0	NORMAL	cam	OSI:25:[Data]	OSI:25:[Data]	http://192.168.0.10/cgi-bin/aw_cam?cmd=OSI:25:0&res=1
	応答	OSI:25:[Data]	1	SLOW				
	要求	QSI:25	2	FAST				
	応答	OSI:25:[Data]	-	-				
ATW TARGET R	制御	OSJ:0D:[Data]	76h	-10	cam	OSJ:0D:[Data]	OSJ:0D:0x[Data]	http://192.168.0.10/cgi-bin/aw_cam?cmd=OSJ:0D:80&res=1
	応答	OSJ:0D:[Data]	80h	0				
	要求	QSJ:0D	-	-				
	応答	OSJ:0D:[Data]	8Ah	+10				
ATW TARGET B	制御	OSJ:0E:[Data]	76h	-10	cam	OSJ:0E:[Data]	OSJ:0E:0x[Data]	http://192.168.0.10/cgi-bin/aw_cam?cmd=OSJ:0E:80&res=1
	応答	OSJ:0E:[Data]	80h	0				
	要求	QSJ:0E	-	-				
	応答	OSJ:0E:[Data]	8Ah	+10				
SHOCKLESS WB SW	制御	OSL:2C:[Data]	0	OFF ON	cam	OSL:2C:[Data]	OSL:2C:[Data]	http://192.168.0.10/cgi-bin/aw_cam?cmd=OSL:2C:1&res=1
	応答	OSL:2C:[Data]						
	要求	QSL:2C						
	応答	OSL:2C:[Data]						
SHOCKLESS WB SPEED	制御	OSL:2D:[Data]	1	1	cam	OSL:2D:[Data]	OSL:2D:[Data]	http://192.168.0.10/cgi-bin/aw_cam?cmd=OSL:2D:1&res=1
	応答	OSL:2D:[Data]	-	-				
	要求	QSL:2D	5	5				
	応答	OSL:2D:[Data]	-	-				
SHUTTER SW	制御	OSG:59:[Data]	0	OFF ON	cam	OSG:59:[Data]	OSG:59:[Data]	http://192.168.0.10/cgi-bin/aw_cam?cmd=OSG:59:1&res=1
	応答	OSG:59:[Data]						
	要求	QSG:59						
	応答	OSG:59:[Data]						
AUTO SHUTTER	制御	OSL:2E:[Data]	0	OFF ON	cam	OSL:2E:[Data]	OSL:2E:[Data]	http://192.168.0.10/cgi-bin/aw_cam?cmd=OSL:2E:1&res=1
	応答	OSL:2E:[Data]						
	要求	QSL:2E						
	応答	OSL:2E:[Data]						
SHUTTER MODE	制御	OSG:5A:[Data]	0	STEP SYNCHRO	cam	OSG:5A:[Data]	OSG:5A:[Data]	http://192.168.0.10/cgi-bin/aw_cam?cmd=OSG:5A:1&res=1
	応答	OSG:5A:[Data]						
	要求	QSG:5A						
	応答	OSG:5A:[Data]						
SHUTTER MODE	制御	OSJ:03:[Data]	0	OFF STEP SYNCHRO ELC	cam	OSJ:03:[Data]	OSJ:03:[Data]	http://192.168.0.10/cgi-bin/aw_cam?cmd=OSJ:03:1&res=1
	応答	OSJ:03:[Data]						
	要求	QSJ:03						
	応答	OSJ:03:[Data]						

コマンド名	種別	コマンド	Data値	設定値	コマンドタイプ	更新通知	camdata.html	使用例・備考
AUTO SHUTTER LIMIT	制御	OSD:BF:[Data]	2 3 4	1/100 1/120 1/250	cam	OSD:BF:[Data]	OSD:BF:[Data]	http://192.168.0.10/cgi-bin/aw_cam?cmd=OSD:BF:2&res=1
	応答	OSD:BF:[Data]						
	要求	QSD:BF						
	応答	OSD:BF:[Data]						
SHUTTER SPEED	制御	OSJ:06:[Data]	0001h - 07D0h	1/1 - 1/2000	cam	OSJ:06:[Data]	OSJ:06:0x[Data]	http://192.168.0.10/cgi-bin/aw_cam?cmd=OSJ:06:0030&res=1 [設定値]の分母の値を[Data] (16進数) で指定 下記のパラメータを設定可能。下記以外を指定した場合はエラー応答する。 [59.94i/59.94p/60pモード] 1/100, 1/120, 1/125, 1/250, 1/500, 1/1000, 1/1500, 1/2000 [50i/50pモード] 1/60, 1/100, 1/125, 1/250, 1/500, 1/1000, 1/1500, 1/2000 [29.97pモード] 1/48, 1/50, 1/60, 1/96, 1/100, 1/120, 1/125, 1/250, 1/500, 1/1000, 1/1500, 1/2000 [25pモード] 1/48, 1/50, 1/60, 1/96, 1/100, 1/125, 1/250, 1/500, 1/1000, 1/1500, 1/2000 [23.98pモード] 1/48, 1/50, 1/60, 1/96, 1/100, 1/120, 1/125, 1/250, 1/500, 1/1000, 1/1500, 1/2000 [59.94p-120fpsモード] 1/125, 1/250, 1/500, 1/1000, 1/1500, 1/2000 [50p-100fpsモード] 1/125, 1/250, 1/500, 1/1000, 1/1500, 1/2000
	応答	OSJ:06:[Data]						
	要求	QSJ:06						
	応答	OSJ:06:[Data]						
SHUTTER SPEED INC	制御	OSJ:04:[Data]	01h - 64h	1 - 100	cam	-	-	http://192.168.0.10/cgi-bin/aw_cam?cmd=OSJ:04:01&res=1 選択可能なSHUTTER SPEEDのうち[Data]段階だけ増加させる OSJ:06の更新通知が送信される
	応答	OSJ:04:[Data]						
	要求	-						
	応答	-						
SHUTTER SPEED DEC	制御	OSJ:05:[Data]	01h - 64h	1 - 100	cam	-	-	http://192.168.0.10/cgi-bin/aw_cam?cmd=OSJ:05:01&res=1 選択可能なSHUTTER SPEEDのうち[Data]段階だけ減少させる OSJ:06の更新通知が送信される
	応答	OSJ:05:[Data]						
	要求	-						
	応答	-						
SYNCHRO SCAN	制御	OSJ:09:[Data]	00000h - 186A0h	0.0[Hz] - 10000.0[Hz]	cam	OSJ:09:[Data]	OSJ:09:0x[Data]	http://192.168.0.10/cgi-bin/aw_cam?cmd=OSJ:09:00258&res=1 [Data] (16進数) は[設定値]の10倍の値を指定する。 パラメータの指定範囲は下記。設定不可能な値を指定した場合は端数を切り捨てる。 [59.94i/59.94p/60p] 60.0Hz~7200Hz [50i/50p] 50.0Hz~7200Hz [29.97p] 30.0Hz~7200Hz [25p] 25.0Hz~7200Hz [23.98p] 24.0Hz~7200Hz [59.94p-120fps] (119.88p) 120.1Hz~7200Hz [50p-100fps] (100p) 100.1Hz~7200Hz
	応答	OSJ:09:[Data]						
	要求	QSJ:09						
	応答	OSJ:09:[Data]						
SYNCHRO SCAN INC	制御	OSJ:07:[Data]	01h - 64h	1 - 100	cam	-	-	http://192.168.0.10/cgi-bin/aw_cam?cmd=OSJ:07:01&res=1 選択可能なSYNCHRO SCANのうち[Data]段階だけ増加させる OSJ:09の更新通知が送信される
	応答	OSJ:07:[Data]						
	要求	-						
	応答	-						

コマンド名	種別	コマンド	Data値	設定値	コマンドタイプ	更新通知	camdata.html	使用例・備考
SYNCHRO SCAN DEC	制御	OSJ:08:[Data]	01h	1	cam	-	-	http://192.168.0.10/cgi-bin/aw_cam?cmd=OSJ:08:01&res=1 選択可能なSYNCHRO SCANのうち[Data]段階だけ減少させる OSJ:09の更新通知が送信される
	応答	OSJ:08:[Data]	-	-				
	要求	-	64h	100				
	応答	-	-	-				
MASTER PEDESTAL	制御	OSJ:0F:[Data]	738h	-200	cam	OSJ:0F:[Data]	OSJ:0F:0x[Data]	http://192.168.0.10/cgi-bin/aw_cam?cmd=OSJ:0F:800&res=1
	応答	OSJ:0F:[Data]	-	-				
	要求	QSJ:0F	800h	0				
	応答	OSJ:0F:[Data]	8C8h	200				
R PEDESTAL	制御	OSG:4C:[Data]	4E0h	-800	cam	OSG:4C:[Data]	OSG:4C:0x[Data]	http://192.168.0.10/cgi-bin/aw_cam?cmd=OSG:4C:800&res=1
	応答	OSG:4C:[Data]	-	-				
	要求	QSG:4C	800h	0				
	応答	OSG:4C:[Data]	B20h	+800				
G PEDESTAL	制御	OSG:4D:[Data]	4E0h	-800	cam	OSG:4D:[Data]	OSG:4D:0x[Data]	http://192.168.0.10/cgi-bin/aw_cam?cmd=OSG:4D:800&res=1
	応答	OSG:4D:[Data]	-	-				
	要求	QSG:4D	800h	0				
	応答	OSG:4D:[Data]	B20h	+800				
B PEDESTAL	制御	OSG:4E:[Data]	4E0h	-800	cam	OSG:4E:[Data]	OSG:4E:0x[Data]	http://192.168.0.10/cgi-bin/aw_cam?cmd=OSG:4E:800&res=1
	応答	OSG:4E:[Data]	-	-				
	要求	QSG:4E	800h	0				
	応答	OSG:4E:[Data]	B20h	+800				
PEDESTAL OFFSET	制御	OSJ:11:[Data]	0	OFF	cam	OSJ:11:[Data]	OSJ:11:[Data]	http://192.168.0.10/cgi-bin/aw_cam?cmd=OSJ:11:0&res=1
	応答	OSJ:11:[Data]	1	ON				
	要求	QSJ:11	-	-				
	応答	OSJ:11:[Data]	-	-				
CHROMA LEVEL SWITCH	制御	OSG:93:[Data]	0	OFF	cam	OSG:93:[Data]	OSG:93:[Data]	http://192.168.0.10/cgi-bin/aw_cam?cmd=OSG:93:1&res=1
	応答	OSG:93:[Data]	1	ON				
	要求	QSG:93	-	-				
	応答	OSG:93:[Data]	-	-				
CHROMA LEVEL	制御	OSL:B0:[Data]	1Ch	-100%	cam	OSL:B0:[Data]	OSL:B0:0x[Data]	http://192.168.0.10/cgi-bin/aw_cam?cmd=OSL:B0:81&res=1 Step:1%
	応答	OSL:B0:[Data]	-	-				
	要求	QSL:B0	80h	0				
	応答	OSL:B0:[Data]	A8h	40				
CHROMA LEVEL	制御	OSD:B0:[Data]	00h	OFF	cam	OSD:B0:[Data]	OSD:B0:0x[Data]	http://192.168.0.10/cgi-bin/aw_cam?cmd=OSD:B0:80&res=1 Step:1%
	応答	OSD:B0:[Data]	1Ch	-100%				
	要求	QSD:B0	80h	0				
	応答	OSD:B0:[Data]	A8h	40				
COLOR TEMP ACH	制御	OSJ:4A:[Data1]:[Data2]	[Data1] 007D0h	[Data1] 2000K	cam	OSJ:4A:[Data1]: Data2]	OSJ:4A:0x[Data1] :[Data2]	http://192.168.0.10/cgi-bin/aw_cam?cmd=OSJ:4A:007D0:0&res=1 設定不可能な値を指定した場合は端数を切り捨てる。
	応答	OSJ:4A:[Data1]:[Data2]	-	-				
	要求	QSJ:4A	03A98h [Data2]	15000K [Data2]				
	応答	OSJ:4A:[Data1]:[Data2]	0	Valid				
COLOR TEMP ACH INC	制御	OSJ:48:[Data]	1h	1	cam	-	-	http://192.168.0.10/cgi-bin/aw_cam?cmd=OSJ:48:1&res=1 選択可能なCOLOR TEMPのうち[Data]段階だけ増加させる OSJ:4Aの更新通知が送信される
	応答	OSJ:48:[Data]	-	-				
	要求	-	Ah	10				
	応答	-	-	-				
COLOR TEMP ACH DEC	制御	OSJ:49:[Data]	1h	1	cam	-	-	http://192.168.0.10/cgi-bin/aw_cam?cmd=OSJ:49:1&res=1 選択可能なCOLOR TEMPのうち[Data]段階だけ減少させる OSJ:4Aの更新通知が送信される
	応答	OSJ:49:[Data]	-	-				
	要求	-	Ah	10				
	応答	-	-	-				

コマンド名	種別	コマンド	Data値	設定値	コマンドタイプ	更新通知	camdata.html	使用例・備考
COLOR TEMP R GAIN ACH	制御	OSJ:4B:[Data]	670h	-400	cam	OSJ:4B:[Data]	OSJ:4B:0x[Data]	http://192.168.0.10/cgi-bin/aw_cam?cmd=OSJ:4B:800&res=1
	応答	OSJ:4B:[Data]	-	-				
	要求	QSJ:4B	800h	0				
	応答	OSJ:4B:[Data]	990h	400				
COLOR TEMP B GAIN ACH	制御	OSJ:4C:[Data]	670h	-400	cam	OSJ:4C:[Data]	OSJ:4C:0x[Data]	http://192.168.0.10/cgi-bin/aw_cam?cmd=OSJ:4C:800&res=1
	応答	OSJ:4C:[Data]	-	-				
	要求	QSJ:4C	800h	0				
	応答	OSJ:4C:[Data]	990h	400				
COLOR TEMP G AXIS ACH	制御	OSJ:4D:[Data]	670h	-400	cam	OSJ:4D:[Data]	OSJ:4D:0x[Data]	http://192.168.0.10/cgi-bin/aw_cam?cmd=OSJ:4D:800&res=1
	応答	OSJ:4D:[Data]	-	-				
	要求	QSJ:4D	800h	0				
	応答	OSJ:4D:[Data]	990h	400				
COLOR TEMP BCH	制御	OSL:2F:[Data1]:[Data2]	[Data1] 007D0h	[Data1] 2000K	cam	OSL:2F:[Data1]:[Data2]	OSL:2F:0x[Data1]:[Data2]	http://192.168.0.10/cgi-bin/aw_cam?cmd=OSL:2F:007D0:0&res=1
	応答	OSL:2F:[Data1]:[Data2]	-	-				
	要求	QSL:2F	03A98h [Data2]	15000K [Data2] Valid				
	応答	OSL:2F:[Data1]:[Data2]	0					
COLOR TEMP BCH INC	制御	OSL:30:[Data]	1h	1	cam	-	-	http://192.168.0.10/cgi-bin/aw_cam?cmd=OSL:30:1&res=1
	応答	OSL:30:[Data]	-	-				
	要求	-	Ah	10				
	応答	-						
COLOR TEMP BCH DEC	制御	OSL:31:[Data]	1h	1	cam	-	-	http://192.168.0.10/cgi-bin/aw_cam?cmd=OSL:31:1&res=1
	応答	OSL:31:[Data]	-	-				
	要求	-	Ah	10				
	応答	-						
COLOR TEMP R GAIN BCH	制御	OSL:32:[Data]	670h	-400	cam	OSL:32:[Data]	OSL:32:0x[Data]	http://192.168.0.10/cgi-bin/aw_cam?cmd=OSL:32:800&res=1
	応答	OSL:32:[Data]	-	-				
	要求	QSL:32	800h	0				
	応答	OSL:32:[Data]	990h	400				
COLOR TEMP B GAIN BCH	制御	OSL:33:[Data]	670h	-400	cam	OSL:33:[Data]	OSL:33:0x[Data]	http://192.168.0.10/cgi-bin/aw_cam?cmd=OSL:33:801&res=1
	応答	OSL:33:[Data]	-	-				
	要求	QSL:33	800h	0				
	応答	OSL:33:[Data]	990h	400				
COLOR TEMP G AXIS BCH	制御	OSL:34:[Data]	670h	-400	cam	OSL:34:[Data]	OSL:34:0x[Data]	http://192.168.0.10/cgi-bin/aw_cam?cmd=OSL:34:801&res=1
	応答	OSL:34:[Data]	-	-				
	要求	QSL:34	800h	0				
	応答	OSL:34:[Data]	990h	400				
G GAIN REL CONTROL SWITCH	制御	OSL:35:[Data]	0 1	OFF	cam	OSL:35:[Data]	OSL:35:[Data]	http://192.168.0.10/cgi-bin/aw_cam?cmd=OSL:35:1&res=1
	応答	OSL:35:[Data]		ON				
	要求	QSL:35						
	応答	OSL:35:[Data]						
RGB GAIN PRESET R GAIN	制御	OSL:36:[Data]	418h	-1000	cam	OSL:36:[Data]	OSL:36:0x[Data]	http://192.168.0.10/cgi-bin/aw_cam?cmd=OSL:36:801&res=1
	応答	OSL:36:[Data]	-	-				
	要求	QSL:36	800h	0				
	応答	OSL:36:[Data]	BE8h	1000				

コマンド名	種別	コマンド	Data値	設定値	コマンドタイプ	更新通知	camdata.html	使用例・備考
RGB GAIN PRESET G GAIN	制御	OSL:37:[Data]	418h	-1000	cam	OSL:37:[Data]	OSL:37:0x[Data]	http://192.168.0.10/cgi-bin/aw_cam?cmd=OSL:37:801&res=1
	応答	OSL:37:[Data]	-	-				
	要求	QSL:37	800h	0				
	応答	OSL:37:[Data]	BE8h	1000				
RGB GAIN PRESET B GAIN	制御	OSL:38:[Data]	418h	-1000	cam	OSL:38:[Data]	OSL:38:0x[Data]	http://192.168.0.10/cgi-bin/aw_cam?cmd=OSL:38:801&res=1
	応答	OSL:38:[Data]	-	-				
	要求	QSL:38	800h	0				
	応答	OSL:38:[Data]	BE8h	1000				
RGB GAIN R GAIN ACH	制御	OSL:39:[Data]	418h	-1000	cam	OSL:39:[Data]	OSL:39:0x[Data]	http://192.168.0.10/cgi-bin/aw_cam?cmd=OSL:39:801&res=1
	応答	OSL:39:[Data]	-	-				
	要求	QSL:39	800h	0				
	応答	OSL:39:[Data]	BE8h	1000				
RGB GAIN G GAIN ACH	制御	OSL:3A:[Data]	418h	-1000	cam	OSL:3A:[Data]	OSL:3A:0x[Data]	http://192.168.0.10/cgi-bin/aw_cam?cmd=OSL:3A:801&res=1
	応答	OSL:3A:[Data]	-	-				
	要求	QSL:3A	800h	0				
	応答	OSL:3A:[Data]	BE8h	1000				
RGB GAIN B GAIN ACH	制御	OSL:3B:[Data]	418h	-1000	cam	OSL:3B:[Data]	OSL:3B:0x[Data]	http://192.168.0.10/cgi-bin/aw_cam?cmd=OSL:3B:801&res=1
	応答	OSL:3B:[Data]	-	-				
	要求	QSL:3B	800h	0				
	応答	OSL:3B:[Data]	BE8h	1000				
RGB GAIN GAIN OFFSET ACH	制御	OSJ:0C:[Data]	0 1	OFF	cam	OSJ:0C:[Data]	OSJ:0C:[Data]	http://192.168.0.10/cgi-bin/aw_cam?cmd=OSJ:0C:0&res=1
	応答	OSJ:0C:[Data]		ON				
	要求	QSL:0C						
	応答	OSJ:0C:[Data]						
RGB GAIN R GAIN BCH	制御	OSL:3C:[Data]	418h	-1000	cam	OSL:3C:[Data]	OSL:3C:0x[Data]	http://192.168.0.10/cgi-bin/aw_cam?cmd=OSL:3C:801&res=1
	応答	OSL:3C:[Data]	-	-				
	要求	QSL:3C	800h	0				
	応答	OSL:3C:[Data]	BE8h	1000				
RGB GAIN G GAIN BCH	制御	OSL:3D:[Data]	418h	-1000	cam	OSL:3D:[Data]	OSL:3D:0x[Data]	http://192.168.0.10/cgi-bin/aw_cam?cmd=OSL:3D:801&res=1
	応答	OSL:3D:[Data]	-	-				
	要求	QSL:3D	800h	0				
	応答	OSL:3D:[Data]	BE8h	1000				
RGB GAIN B GAIN BCH	制御	OSL:3E:[Data]	418h	-1000	cam	OSL:3E:[Data]	OSL:3E:0x[Data]	http://192.168.0.10/cgi-bin/aw_cam?cmd=OSL:3E:801&res=1
	応答	OSL:3E:[Data]	-	-				
	要求	QSL:3E	800h	0				
	応答	OSL:3E:[Data]	BE8h	1000				
RGB GAIN GAIN OFFSET BCH	制御	OSL:3F:[Data]	0 1	OFF	cam	OSL:3F:[Data]	OSL:3F:[Data]	http://192.168.0.10/cgi-bin/aw_cam?cmd=OSL:3F:1&res=1
	応答	OSL:3F:[Data]		ON				
	要求	QSL:3F						
	応答	OSL:3F:[Data]						
FLARE	制御	OSA:11:[Data]	0 1	OFF	cam	OSA:11:[Data]	OSA:11:[Data]	http://192.168.0.10/cgi-bin/aw_cam?cmd=OSA:11:1&res=1
	応答	OSA:11:[Data]		ON				
	要求	QSA:11						
	応答	OSA:11:[Data]						
MASTER FLARE	制御	OSL:40:[Data]	738h	-200	cam	OSL:40:[Data]	OSL:40:0x[Data]	http://192.168.0.10/cgi-bin/aw_cam?cmd=OSL:40:801&res=1
	応答	OSL:40:[Data]	-	-				
	要求	QSL:40	800h	0				
	応答	OSL:40:[Data]	8C8h	200				

コマンド名	種別	コマンド	Data値	設定値	コマンドタイプ	更新通知	camdata.html	使用例・備考
R FLARE	制御	OSL:41:[Data]	738h	-200	cam	OSL:41:[Data]	OSL:41:0x[Data]	http://192.168.0.10/cgi-bin/aw_cam?cmd=OSL:41:801&res=1
	応答	OSL:41:[Data]	-	-				
	要求	QSL:41	800h	0				
	応答	OSL:41:[Data]	8C8h	200				
G FLARE	制御	OSL:42:[Data]	738h	-200	cam	OSL:42:[Data]	OSL:42:0x[Data]	http://192.168.0.10/cgi-bin/aw_cam?cmd=OSL:42:801&res=1
	応答	OSL:42:[Data]	-	-				
	要求	QSL:42	800h	0				
	応答	OSL:42:[Data]	8C8h	200				
B FLARE	制御	OSL:43:[Data]	738h	-200	cam	OSL:43:[Data]	OSL:43:0x[Data]	http://192.168.0.10/cgi-bin/aw_cam?cmd=OSL:43:801&res=1
	応答	OSL:43:[Data]	-	-				
	要求	QSL:43	800h	0				
	応答	OSL:43:[Data]	8C8h	200				
GAMMA	制御	OSA:0A:[Data]	0	OFF	cam	OSA:0A:[Data]	OSA:0A:[Data]	http://192.168.0.10/cgi-bin/aw_cam?cmd=OSA:0A:1&res=1
	応答	OSA:0A:[Data]		ON				
	要求	QSA:0A						
	応答	OSA:0A:[Data]						
GAMMA MODE SELECT	制御	OSJ:D7:[Data]	00	HD	cam	OSJ:D7:[Data]	OSJ:D7:[Data]	http://192.168.0.10/cgi-bin/aw_cam?cmd=OSJ:D7:00&res=1
	応答	OSJ:D7:[Data]	01	NORMAL				
	要求	QSJ:D7	02	CINEMA1				
	応答	OSJ:D7:[Data]	03	CINEMA2				
MASTER GAMMA	制御	OSA:6A:[Data]	58h	0.15	cam	OSA:6A:[Data]	OSA:6A:0x[Data]	http://192.168.0.10/cgi-bin/aw_cam?cmd=OSA:6A:67&res=1 Step: 0.01
	応答	OSA:6A:[Data]	-	-				
	要求	QSA:6A	94h	0.75				
	応答	OSA:6A:[Data]						
R GAMMA	制御	OSI:35:[Data]	35h	-75	cam	OSI:35:[Data]	OSI:35:0x[Data]	http://192.168.0.10/cgi-bin/aw_cam?cmd=OSI:35:81&res=1
	応答	OSI:35:[Data]	80h	0				
	要求	QSI:35	-	-				
	応答	OSI:35:[Data]	CBh	+75				
B GAMMA	制御	OSI:36:[Data]	35h	-75	cam	OSI:36:[Data]	OSI:36:0x[Data]	http://192.168.0.10/cgi-bin/aw_cam?cmd=OSI:36:81&res=1
	応答	OSI:36:[Data]	80h	0				
	要求	QSI:36	-	-				
	応答	OSI:36:[Data]	CBh	+75				
BLACK GAMMA	制御	OSA:0B:[Data]	0	OFF	cam	OSA:0B:[Data]	OSA:0B:[Data]	http://192.168.0.10/cgi-bin/aw_cam?cmd=OSA:0B:1&res=1
	応答	OSA:0B:[Data]		ON				
	要求	QSA:0B						
	応答	OSA:0B:[Data]						
MASTER BLACK GAMMA	制御	OSA:07:[Data]	50h	-48	cam	OSA:07:[Data]	OSA:07:0x[Data]	http://192.168.0.10/cgi-bin/aw_cam?cmd=OSA:07:81&res=1
	応答	OSA:07:[Data]	80h	0				
	要求	QSA:07	-	-				
	応答	OSA:07:[Data]	B0h	+48				
R BLACK GAMMA	制御	OSA:08:[Data]	6Ch	-20	cam	OSA:08:[Data]	OSA:08:0x[Data]	http://192.168.0.10/cgi-bin/aw_cam?cmd=OSA:08:81&res=1
	応答	OSA:08:[Data]	-	-				
	要求	QSA:08	80h	0				
	応答	OSA:08:[Data]	94h	+20				

コマンド名	種別	コマンド	Data値	設定値	コマンドタイプ	更新通知	camdata.html	使用例・備考
B BLACK GAMMA	制御	OSA:09:[Data]	6Ch	-20	cam	OSA:09:[Data]	OSA:09:0x[Data]	http://192.168.0.10/cgi-bin/aw_cam?cmd=OSA:09:81&res=1
	応答	OSA:09:[Data]	-	-				
	要求	QSA:09	80h	0				
	応答	OSA:09:[Data]	94h	+20				
BLACK GAMMA RANGE	制御	OSJ:1B:[Data]	1	1	cam	OSJ:1B:[Data]	OSJ:1B:[Data]	http://192.168.0.10/cgi-bin/aw_cam?cmd=OSJ:1B:1&res=1
	応答	OSJ:1B:[Data]	2	2				
	要求	QSJ:1B	3	3				
	応答	OSJ:1B:[Data]						
INITIAL GAMMA	制御	OSL:44:[Data]	8h	4.0	cam	OSL:44:[Data]	OSL:44:0x[Data]	http://192.168.0.10/cgi-bin/aw_cam?cmd=OSL:44:8&res=1
	応答	OSL:44:[Data]	9h	4.5				
	要求	QSL:44	Ah	5.0				
	応答	OSL:44:[Data]						
KNEE	制御	OSL:45:[Data]	0	OFF	cam	OSL:45:[Data]	OSL:45:[Data]	http://192.168.0.10/cgi-bin/aw_cam?cmd=OSL:45:1&res=1
	応答	OSL:45:[Data]		ON				
	要求	QSL:45						
	応答	OSL:45:[Data]						
KNEE MODE	制御	OSL:46:[Data]	0	MANUAL	cam	OSL:46:[Data]	OSL:46:[Data]	http://192.168.0.10/cgi-bin/aw_cam?cmd=OSL:46:1&res=1
	応答	OSL:46:[Data]		AUTO				
	要求	QSL:46						
	応答	OSL:46:[Data]						
KNEE MODE	制御	OSA:2D:[Data]	0	OFF	cam	OSA:2D:[Data]	OSA:2D:[Data]	http://192.168.0.10/cgi-bin/aw_cam?cmd=OSA:2D:0&res=1
	応答	OSA:2D:[Data]		MANUAL				
	要求	QSA:2D		AUTO				
	応答	OSA:2D:[Data]						
KNEE MASTER POINT	制御	OSA:20:[Data]	4Ah	80.00%	cam	OSA:20:[Data]	OSA:20:0x[Data]	http://192.168.0.10/cgi-bin/aw_cam?cmd=OSA:20:4A&res=1 Step : 0.25%
	応答	OSA:20:[Data]	-	-				
	要求	QSA:20						
	応答	OSA:20:[Data]	C2h	110.00%				
KNEE R POINT	制御	OSA:22:[Data]	1Ch	-25.00%	cam	OSA:22:[Data]	OSA:22:0x[Data]	http://192.168.0.10/cgi-bin/aw_cam?cmd=OSA:22:80&res=1 Step : 0.25%
	応答	OSA:22:[Data]	80h	0.00%				
	要求	QSA:22	-	-				
	応答	OSA:22:[Data]	E4h	+25.00%				
KNEE B POINT	制御	OSA:23:[Data]	1Ch	-25.00%	cam	OSA:23:[Data]	OSA:23:0x[Data]	http://192.168.0.10/cgi-bin/aw_cam?cmd=OSA:23:80&res=1 Step : 0.25%
	応答	OSA:23:[Data]	80h	0.00%				
	要求	QSA:23	-	-				
	応答	OSA:23:[Data]	E4h	+25.00%				
KNEE MASTER SLOPE	制御	OSA:24:[Data]	00h	0	cam	OSA:24:[Data]	OSA:24:0x[Data]	http://192.168.0.10/cgi-bin/aw_cam?cmd=OSA:24:00&res=1
	応答	OSA:24:[Data]	-	-				
	要求	QSA:24	C7h	199				
	応答	OSA:24:[Data]						
KNEE R SLOPE	制御	OSA:26:[Data]	1Dh	-99	cam	OSA:26:[Data]	OSA:26:0x[Data]	http://192.168.0.10/cgi-bin/aw_cam?cmd=OSA:26:81&res=1
	応答	OSA:26:[Data]	-	-				
	要求	QSA:26	80h	0				
	応答	OSA:26:[Data]	E3h	+99				
KNEE B SLOPE	制御	OSA:27:[Data]	1Dh	-99	cam	OSA:27:[Data]	OSA:27:0x[Data]	http://192.168.0.10/cgi-bin/aw_cam?cmd=OSA:27:81&res=1
	応答	OSA:27:[Data]	-	-				
	要求	QSA:27	80h	0				
	応答	OSA:27:[Data]	E3h	+99				
AUTO KNEE RESPONSE	制御	OSG:97:[Data]	1	1	cam	OSG:97:[Data]	OSG:97:[Data]	http://192.168.0.10/cgi-bin/aw_cam?cmd=OSG:97:1&res=1
	応答	OSG:97:[Data]	-	-				
	要求	QSG:97	8	8				
	応答	OSG:97:[Data]						

コマンド名	種別	コマンド	Data値	設定値	コマンドタイプ	更新通知	camdata.html	使用例・備考
WHITE CLIP	制御	OSA:2E:[Data]	0 1	OFF ON	cam	OSA:2E:[Data]	OSA:2E:[Data]	http://192.168.0.10/cgi-bin/aw_cam?cmd=OSA:2E:0&res=1
	応答	OSA:2E:[Data]						
	要求	QSA:2E						
	応答	OSA:2E:[Data]						
MASTER WHITE CLIP LEVEL	制御	OSA:2A:[Data]	50h - 6Dh	80% - 109%	cam	OSA:2A:[Data]	OSA:2A:0x[Data]	http://192.168.0.10/cgi-bin/aw_cam?cmd=OSA:2A:00&res=1 Step: 1%
	応答	OSA:2A:[Data]						
	要求	QSA:2A						
	応答	OSA:2A:[Data]						
R WHITE CLIP LEVEL	制御	OSL:47:[Data]	71h - 80h - 8Fh	-15% - 0% - 15%	cam	OSL:47:[Data]	OSL:47:0x[Data]	http://192.168.0.10/cgi-bin/aw_cam?cmd=OSL:47:81&res=1
	応答	OSL:47:[Data]						
	要求	QSL:47						
	応答	OSL:47:[Data]						
B WHITE CLIP LEVEL	制御	OSL:48:[Data]	71h - 80h - 8Fh	-15% - 0% - 15%	cam	OSL:48:[Data]	OSL:48:0x[Data]	http://192.168.0.10/cgi-bin/aw_cam?cmd=OSL:48:81&res=1
	応答	OSL:48:[Data]						
	要求	QSL:48						
	応答	OSL:48:[Data]						
HI-COLOR	制御	OSL:49:[Data]	0 1	OFF ON	cam	OSL:49:[Data]	OSL:49:[Data]	http://192.168.0.10/cgi-bin/aw_cam?cmd=OSL:49:1&res=1
	応答	OSL:49:[Data]						
	要求	QSL:49						
	応答	OSL:49:[Data]						
HI-COLOR LEVEL	制御	OSL:4A:[Data]	01h - 20h	1 - 32	cam	OSL:4A:[Data]	OSL:4A:0x[Data]	http://192.168.0.10/cgi-bin/aw_cam?cmd=OSL:4A:01&res=1
	応答	OSL:4A:[Data]						
	要求	QSL:4A						
	応答	OSL:4A:[Data]						
DRS	制御	OSA:0D:[Data]	0 1	OFF ON	cam	OSA:0D:[Data]	OSA:0D:[Data]	http://192.168.0.10/cgi-bin/aw_cam?cmd=OSA:0D:1&res=1
	応答	OSA:0D:[Data]						
	要求	QSA:0D						
	応答	OSA:0D:[Data]						
DRS EFFECT DEPTH	制御	OSL:4B:[Data]	1 - 5	1 - 5	cam	OSL:4B:[Data]	OSL:4B:[Data]	http://192.168.0.10/cgi-bin/aw_cam?cmd=OSL:4B:1&res=1
	応答	OSL:4B:[Data]						
	要求	QSL:4B						
	応答	OSL:4B:[Data]						
DETAIL	制御	ODT:[Data]	0 1 2	OFF ON ON	cam	ODT:[Data]	ODT:[Data]	http://192.168.0.10/cgi-bin/aw_cam?cmd=ODT:1&res=1
	応答	ODT:[Data]						
	要求	QDT						
	応答	ODT:[Data]						
MASTER DETAIL	制御	OSA:30:[Data]	61h - 80h - 9Fh	-31 - 0 - +31	cam	OSA:30:[Data]	OSA:30:[Data]	http://192.168.0.10/cgi-bin/aw_cam?cmd=OSA:30:80&res=1
	応答	OSA:30:[Data]						
	要求	QSA:30						
	応答	OSA:30:[Data]						
DETAIL PEAK FREQUENCY	制御	OSG:30:[Data]	01h - 08h	1 - 8	cam	OSG:30:[Data]	OSG:30:0x[Data]	http://192.168.0.10/cgi-bin/aw_cam?cmd=OSG:30:01&res=1
	応答	OSG:30:[Data]						
	要求	QSG:30						
	応答	OSG:30:[Data]						
DETAIL CRISP	制御	OSD:22:[Data]	00h - 3Fh	0 - 63	cam	OSD:22:[Data]	OSD:22:0x[Data]	http://192.168.0.10/cgi-bin/aw_cam?cmd=OSD:22:01&res=1
	応答	OSD:22:[Data]						
	要求	QSD:22						
	応答	OSD:22:[Data]						
DETAIL GAIN(+)	制御	OSA:38:[Data]	61h - 80h - 9Fh	-31 - 0 - +31	cam	OSA:38:[Data]	OSA:38:0x[Data]	http://192.168.0.10/cgi-bin/aw_cam?cmd=OSA:38:80&res=1
	応答	OSA:38:[Data]						
	要求	QSA:38						
	応答	OSA:38:[Data]						

コマンド名	種別	コマンド	Data値	設定値	コマンドタイプ	更新通知	camdata.html	使用例・備考
DETAIL GAIN(-)	制御	OSA:39:[Data]	61h	-31	cam	OSA:39:[Data]	OSA:39:0x[Data]	http://192.168.0.10/cgi-bin/aw_cam?cmd=OSA:39:80&res=1
	応答	OSA:39:[Data]	-	-				
	要求	QSA:39	80h	0				
	応答	OSA:39:[Data]	9Fh	+31				
DETAIL CLIP(+)	制御	OSG:40:[Data]	00h	0	cam	OSG:40:[Data]	OSG:40:0x[Data]	http://192.168.0.10/cgi-bin/aw_cam?cmd=OSG:40:01&res=1
	応答	OSG:40:[Data]	-	-				
	要求	QSG:40	3Fh	63				
	応答	OSG:40:[Data]	3Fh	63				
DETAIL CLIP(-)	制御	OSG:41:[Data]	00h	0	cam	OSG:41:[Data]	OSG:41:0x[Data]	http://192.168.0.10/cgi-bin/aw_cam?cmd=OSG:41:01&res=1
	応答	OSG:41:[Data]	-	-				
	要求	QSG:41	3Fh	63				
	応答	OSG:41:[Data]	3Fh	63				
DETAIL KNEE APERTURE LEVEL	制御	OSG:3F:[Data]	00h	0	cam	OSG:3F:[Data]	OSG:3F:0x[Data]	http://192.168.0.10/cgi-bin/aw_cam?cmd=OSG:3F:00&res=1
	応答	OSG:3F:[Data]	-	-				
	要求	QSG:3F	27h	39				
	応答	OSG:3F:[Data]	27h	39				
DETAIL KNEE	制御	OSL:4C:[Data]	00h	00	cam	OSL:4C:[Data]	OSL:4C:0x[Data]	http://192.168.0.10/cgi-bin/aw_cam?cmd=OSL:4C:01&res=1
	応答	OSL:4C:[Data]	-	-				
	要求	QSL:4C	0Fh	15				
	応答	OSL:4C:[Data]	0Fh	15				
DETAIL LEVEL DEPENDENT SWITCH	制御	OSG:3E:[Data]	0	OFF	cam	OSG:3E:[Data]	OSG:3E:[Data]	http://192.168.0.10/cgi-bin/aw_cam?cmd=OSG:3E:1&res=1
	応答	OSG:3E:[Data]	1	ON				
	要求	QSG:3E	1	ON				
	応答	OSG:3E:[Data]	1	ON				
DETAIL LEVEL DEPENDENT	制御	OSD:26:[Data]	00h	00	cam	OSD:26:[Data]	OSD:26:0x[Data]	http://192.168.0.10/cgi-bin/aw_cam?cmd=OSD:26:01&res=1
	応答	OSD:26:[Data]	-	-				
	要求	QSD:26	0Fh	15				
	応答	OSD:26:[Data]	0Fh	15				
DARK DETAIL SWITCH	制御	OSL:4D:[Data]	0	OFF	cam	OSL:4D:[Data]	OSL:4D:[Data]	http://192.168.0.10/cgi-bin/aw_cam?cmd=OSL:4D:1&res=1
	応答	OSL:4D:[Data]	1	ON				
	要求	QSL:4D	1	ON				
	応答	OSL:4D:[Data]	1	ON				
DARK DETAIL	制御	OSL:4E:[Data]	0	0	cam	OSL:4E:[Data]	OSL:4E:[Data]	http://192.168.0.10/cgi-bin/aw_cam?cmd=OSL:4E:1&res=1
	応答	OSL:4E:[Data]	-	-				
	要求	QSL:4E	7	7				
	応答	OSL:4E:[Data]	7	7				
DOWNCON CHROMA LEVEL SWITCH	制御	OSL:4F:[Data]	0	OFF	cam	OSL:4F:[Data]	OSL:4F:[Data]	http://192.168.0.10/cgi-bin/aw_cam?cmd=OSL:4F:1&res=1
	応答	OSL:4F:[Data]	1	ON				
	要求	QSL:4F	1	ON				
	応答	OSL:4F:[Data]	1	ON				
DOWNCON CHROMA LEVEL	制御	OSL:50:[Data]	1Ch	-100%	cam	OSL:50:[Data]	OSL:50:0x[Data]	http://192.168.0.10/cgi-bin/aw_cam?cmd=OSL:50:81&res=1
	応答	OSL:50:[Data]	-	-				
	要求	QSL:50	80h	0%				
	応答	OSL:50:[Data]	A8h	40%				
DOWNCON DETAIL	制御	OSJ:14:[Data]	0	OFF	cam	OSJ:14:[Data]	OSJ:14:0x[Data]	http://192.168.0.10/cgi-bin/aw_cam?cmd=OSJ:14:0&res=1
	応答	OSJ:14:[Data]	1	ON				
	要求	QSJ:14	1	ON				
	応答	OSJ:14:[Data]	1	ON				
DOWNCON MASTER DETAIL	制御	OSJ:15:[Data]	61h	-31	cam	OSJ:15:[Data]	OSJ:15:0x[Data]	http://192.168.0.10/cgi-bin/aw_cam?cmd=OSJ:15:80&res=1
	応答	OSJ:15:[Data]	-	-				
	要求	QSJ:15	80h	0				
	応答	OSJ:15:[Data]	-	-				
DOWNCON H DETAIL LEVEL	制御	OSL:51:[Data]	80h	00	cam	OSL:51:[Data]	OSL:51:0x[Data]	http://192.168.0.10/cgi-bin/aw_cam?cmd=OSL:51:81&res=1
	応答	OSL:51:[Data]	-	-				
	要求	QSL:51	BFh	63				
	応答	OSL:51:[Data]	BFh	63				

コマンド名	種別	コマンド	Data値	設定値	コマンドタイプ	更新通知	camdata.html	使用例・備考
DOWNCON V DETAIL LEVEL	制御	OSJ:17:[Data]	80h	00	cam	OSJ:17:[Data]	OSJ:17:0x[Data]	http://192.168.0.10/cgi-bin/aw_cam?cmd=OSJ:17:80&res=1
	応答	OSJ:17:[Data]	-	-				
	要求	QSL:17	BfH	63				
	応答	OSJ:17:[Data]						
DOWNCON PEAK FREQUENCY	制御	OSL:52:[Data]	07Ch	12.4MHz	cam	OSL:52:[Data]	OSL:52:0x[Data]	http://192.168.0.10/cgi-bin/aw_cam?cmd=OSL:52:07C&res=1 ・ [Data]は設定値の10倍を16進数変換したもの ・ 以下の設定値のみ設定可能 12.4, 12.5, 12.7, 12.9, 13.0, 13.3, 13.6, 13.9, 14.2, 14.6, 15.0, 15.5, 16.1, 16.7, 17.3, 18.3, 18.6, 18.8, 19.0, 19.2, 19.5, 19.9, 20.3, 20.9, 21.5, 22.4, 23.6, 25.4, 28.6, 37.1MHz
	応答	OSL:52:[Data]	-	-				
	要求	QSL:52	173h	37.1MHz				
	応答	OSL:52:[Data]						
DOWNCON V DETAIL FREQUENCY	制御	OSL:53:[Data]	00h	00	cam	OSL:53:[Data]	OSL:53:0x[Data]	http://192.168.0.10/cgi-bin/aw_cam?cmd=OSL:53:01&res=1
	応答	OSL:53:[Data]	-	-				
	要求	QSL:53	1Fh	31				
	応答	OSL:53:[Data]						
DOWNCON CRISP	制御	OSL:54:[Data]	80h	00	cam	OSL:54:[Data]	OSL:54:0x[Data]	http://192.168.0.10/cgi-bin/aw_cam?cmd=OSL:54:81&res=1
	応答	OSL:54:[Data]	-	-				
	要求	QSL:54	BfH	63				
	応答	OSL:54:[Data]						
DOWNCON DETAIL CLIP(+)	制御	OSL:57:[Data]	80h	00	cam	OSL:57:[Data]	OSL:57:0x[Data]	http://192.168.0.10/cgi-bin/aw_cam?cmd=OSL:57:81&res=1
	応答	OSL:57:[Data]	-	-				
	要求	QSL:57	BfH	63				
	応答	OSL:57:[Data]						
DOWNCON DETAIL CLIP(-)	制御	OSL:58:[Data]	80h	00	cam	OSL:58:[Data]	OSL:58:0x[Data]	http://192.168.0.10/cgi-bin/aw_cam?cmd=OSL:58:81&res=1
	応答	OSL:58:[Data]	-	-				
	要求	QSL:58	BfH	63				
	応答	OSL:58:[Data]						
DOWNCON KNEE APERTURE LEVEL	制御	OSL:5A:[Data]	00h	0	cam	OSL:5A:[Data]	OSL:5A:0x[Data]	http://192.168.0.10/cgi-bin/aw_cam?cmd=OSL:5A:01&res=1
	応答	OSL:5A:[Data]	-	-				
	要求	QSL:5A	27h	39				
	応答	OSL:5A:[Data]						
DOWNCON DETAIL KNEE	制御	OSL:5B:[Data]	00h	00	cam	OSL:5B:[Data]	OSL:5B:0x[Data]	http://192.168.0.10/cgi-bin/aw_cam?cmd=OSL:5B:01&res=1
	応答	OSL:5B:[Data]	-	-				
	要求	QSL:5B	0Fh	15				
	応答	OSL:5B:[Data]						
DOWNCON LEVEL DEPENDENT SWITCH	制御	OSL:5C:[Data]	0	OFF	cam	OSL:5C:[Data]	OSL:5C:[Data]	http://192.168.0.10/cgi-bin/aw_cam?cmd=OSL:5C:1&res=1
	応答	OSL:5C:[Data]	1	ON				
	要求	QSL:5C						
	応答	OSL:5C:[Data]						
DOWNCON LEVEL DEPENDENT	制御	OSL:5D:[Data]	00h	00	cam	OSL:5D:[Data]	OSL:5D:0x[Data]	http://192.168.0.10/cgi-bin/aw_cam?cmd=OSL:5D:01&res=1
	応答	OSL:5D:[Data]	-	-				
	要求	QSL:5D	0Fh	15				
	応答	OSL:5D:[Data]						
DOWNCON DARK DETAIL SWITCH	制御	OSL:5E:[Data]	0	OFF	cam	OSL:5E:[Data]	OSL:5E:[Data]	http://192.168.0.10/cgi-bin/aw_cam?cmd=OSL:5E:1&res=1
	応答	OSL:5E:[Data]	1	ON				
	要求	QSL:5E						
	応答	OSL:5E:[Data]						
DOWNCON DARK DETAIL	制御	OSL:5F:[Data]	0	0	cam	OSL:5F:[Data]	OSL:5F:[Data]	http://192.168.0.10/cgi-bin/aw_cam?cmd=OSL:5F:1&res=1
	応答	OSL:5F:[Data]	-	-				
	要求	QSL:5F	7	7				
	応答	OSL:5F:[Data]						
DOWNCON SKIN TONE DETAIL	制御	OSL:60:[Data]	0	OFF	cam	OSL:60:[Data]	OSL:60:[Data]	http://192.168.0.10/cgi-bin/aw_cam?cmd=OSL:60:1&res=1
	応答	OSL:60:[Data]	1	ON				
	要求	QSL:60						
	応答	OSL:60:[Data]						
DOWNCON SKIN TONE DETAIL MEMORY SELECT	制御	OSL:B1:[Data]	0	A	cam	OSL:B1:[Data]	OSL:B1:[Data]	http://192.168.0.10/cgi-bin/aw_cam?cmd=OSL:B1:1&res=1
	応答	OSL:B1:[Data]	1	B				
	要求	QSL:B1	2	C				
	応答	OSL:B1:[Data]						

コマンド名	種別	コマンド	Data値	設定値	コマンドタイプ	更新通知	camdata.html	使用例・備考
DOWNCON ZEBRA	制御	OSL:61:[Data]	0 1	OFF ON	cam	OSL:61:[Data]	OSL:61:[Data]	http://192.168.0.10/cgi-bin/aw_cam?cmd=OSL:61:1&res=1
	応答	OSL:61:[Data]						
	要求	QSL:61						
	応答	OSL:61:[Data]						
DOWNCON ZEBRA EFFECT MEMORY	制御	OSL:62:[Data]	0 1 2 3 4 5 6	A B C A+B A+C B+C A+B+C	cam	OSL:62:[Data]	OSL:62:[Data]	http://192.168.0.10/cgi-bin/aw_cam?cmd=OSL:62:1&res=1
	応答	OSL:62:[Data]						
	要求	QSL:62						
	応答	OSL:62:[Data]						
	制御	OSL:62:[Data]						
DOWNCON SKIN TONE EFFECT MEMORY	制御	OSL:63:[Data]	0 1 2 3 4 5 6	A B C A+B A+C B+C A+B+C	cam	OSL:63:[Data]	OSL:63:[Data]	http://192.168.0.10/cgi-bin/aw_cam?cmd=OSL:63:1&res=1
	応答	OSL:63:[Data]						
	要求	QSL:63						
	応答	OSL:63:[Data]						
	制御	OSL:63:[Data]						
DOWNCON SKIN TONE CRISP	制御	OSL:64:[Data]	80h - 88h	0 - 8	cam	OSL:64:[Data]	OSL:64:0x[Data]	http://192.168.0.10/cgi-bin/aw_cam?cmd=OSL:64:81&res=1
	応答	OSL:64:[Data]						
	要求	QSL:64						
	応答	OSL:64:[Data]						
DOWNCON I CENTER	制御	OSL:65:[Data]	00h - FFh	0 - 255	cam	OSL:65:[Data]	OSL:65:0x[Data]	http://192.168.0.10/cgi-bin/aw_cam?cmd=OSL:65:01&res=1
	応答	OSL:65:[Data]						
	要求	QSL:65						
	応答	OSL:65:[Data]						
DOWNCON I WIDTH	制御	OSL:66:[Data]	00h - FFh	0 - 255	cam	OSL:66:[Data]	OSL:66:0x[Data]	http://192.168.0.10/cgi-bin/aw_cam?cmd=OSL:66:01&res=1
	応答	OSL:66:[Data]						
	要求	QSL:66						
	応答	OSL:66:[Data]						
DOWNCON Q WIDTH	制御	OSL:67:[Data]	00h - 7Fh	0 - 127	cam	OSL:67:[Data]	OSL:67:0x[Data]	http://192.168.0.10/cgi-bin/aw_cam?cmd=OSL:67:01&res=1
	応答	OSL:67:[Data]						
	要求	QSL:67						
	応答	OSL:67:[Data]						
DOWNCON Q PHASE	制御	OSL:68:[Data]	000h - 167h	0 - 359	cam	OSL:68:[Data]	OSL:68:0x[Data]	http://192.168.0.10/cgi-bin/aw_cam?cmd=OSL:68:001&res=1
	応答	OSL:68:[Data]						
	要求	QSL:68						
	応答	OSL:68:[Data]						
SKIN TONE DETAIL	制御	OSA:40:[Data]	0 1	OFF ON	cam	OSA:40:[Data]	OSA:40:[Data]	http://192.168.0.10/cgi-bin/aw_cam?cmd=OSA:40:0&res=1
	応答	OSA:40:[Data]						
	要求	QSA:40						
	応答	OSA:40:[Data]						
SKIN TONE DETAIL MEMORY SELECT	制御	OSL:69:[Data]	0 1 2	A B C	cam	OSL:69:[Data]	OSL:69:[Data]	http://192.168.0.10/cgi-bin/aw_cam?cmd=OSL:69:1&res=1
	応答	OSL:69:[Data]						
	要求	QSL:69						
	応答	OSL:69:[Data]						
ZEBRA	制御	OSA:49:[Data]	0 1	OFF ON	cam	OSA:49:[Data]	OSA:49:[Data]	http://192.168.0.10/cgi-bin/aw_cam?cmd=OSA:49:1&res=1
	応答	OSA:49:[Data]						
	要求	QSA:49						
	応答	OSA:49:[Data]						
ZEBRA EFFECT MEMORY	制御	OSL:6A:[Data]	0 1 2 3 4 5 6	A B C A+B A+C B+C A+B+C	cam	OSL:6A:[Data]	OSL:6A:[Data]	http://192.168.0.10/cgi-bin/aw_cam?cmd=OSL:6A:1&res=1
	応答	OSL:6A:[Data]						
	要求	QSL:6A						
	応答	OSL:6A:[Data]						
	制御	OSL:6A:[Data]						
	応答	OSL:6A:[Data]						

コマンド名	種別	コマンド	Data値	設定値	コマンドタイプ	更新通知	camdata.html	使用例・備考
SKIN TONE EFFECT MEMORY	制御	OSG:48:[Data]	0	A	cam	OSG:48:[Data]	OSG:48:[Data]	http://192.168.0.10/cgi-bin/aw_cam?cmd=OSG:48:1&res=1
	応答	OSG:48:[Data]	1	B				
	要求	QSG:48	2	C				
	応答	OSG:48:[Data]	3	A+B				
SKIN TONE CRISP	制御	OSG:49:[Data]	41h	-63	cam	OSG:49:[Data]	OSG:49:0x[Data]	http://192.168.0.10/cgi-bin/aw_cam?cmd=OSG:49:81&res=1
	応答	OSG:49:[Data]	-	-				
	要求	QSG:49	80h	0				
	応答	OSG:49:[Data]	-	-				
SKIN TONE DETAIL I CENTER	制御	OSA:45:[Data]	00h	0	cam	OSA:45:[Data]	OSA:45:0x[Data]	http://192.168.0.10/cgi-bin/aw_cam?cmd=OSA:45:01&res=1
	応答	OSA:45:[Data]	-	-				
	要求	QSA:45	-	-				
	応答	OSA:45:[Data]	FFh	255				
SKIN TONE DETAIL I WIDTH	制御	OSA:46:[Data]	00h	0	cam	OSA:46:[Data]	OSA:46:0x[Data]	http://192.168.0.10/cgi-bin/aw_cam?cmd=OSA:46:01&res=1
	応答	OSA:46:[Data]	-	-				
	要求	QSA:46	-	-				
	応答	OSA:46:[Data]	FFh	255				
SKIN TONE DETAIL Q WIDTH	制御	OSA:47:[Data]	00h	0	cam	OSA:47:[Data]	OSA:47:0x[Data]	http://192.168.0.10/cgi-bin/aw_cam?cmd=OSA:47:01&res=1
	応答	OSA:47:[Data]	-	-				
	要求	QSA:47	-	-				
	応答	OSA:47:[Data]	FFh	255				
SKIN TONE DETAIL Q PHASE	制御	OSG:4F:[Data]	000h	0	cam	OSG:4F:[Data]	OSG:4F:0x[Data]	http://192.168.0.10/cgi-bin/aw_cam?cmd=OSA:4F:001&res=1
	応答	OSG:4F:[Data]	-	-				
	要求	QSG:4F	-	-				
	応答	OSG:4F:[Data]	167h	359				
PRESET MATRIX	制御	OSE:31:[Data]	0	NORMAL	cam	OSE:31:[Data]	OSE:31:[Data]	http://192.168.0.10/cgi-bin/aw_cam?cmd=OSE:31:0&res=1
	応答	OSE:31:[Data]	1	CINEMA1				
	要求	QSE:31	2	CINEMA2				
	応答	OSE:31:[Data]	3	USER				
MATRIX	制御	OSA:84:[Data]	0	OFF	cam	OSA:84:[Data]	OSA:84:[Data]	http://192.168.0.10/cgi-bin/aw_cam?cmd=OSA:84:1&res=1
	応答	OSA:84:[Data]	-	ON				
	要求	QSA:84	1	ON				
	応答	OSA:84:[Data]	-	ON				
LINEAR MATRIX	制御	OSL:6C:[Data]	0	OFF	cam	OSL:6C:[Data]	OSL:6C:[Data]	http://192.168.0.10/cgi-bin/aw_cam?cmd=OSL:6C:1&res=1
	応答	OSL:6C:[Data]	-	ON				
	要求	QSL:6C	1	ON				
	応答	OSL:6C:[Data]	-	ON				
LINEAR TABLE	制御	OSA:00:[Data]	0	A	cam	OSA:00:[Data]	OSA:00:[Data]	http://192.168.0.10/cgi-bin/aw_cam?cmd=OSA:00:1&res=1
	応答	OSA:00:[Data]	-	B				
	要求	QSA:00	1	B				
	応答	OSA:00:[Data]	-	B				
COLOR CORRECT	制御	OSA:85:[Data]	0	OFF	cam	OSA:85:[Data]	OSA:85:[Data]	http://192.168.0.10/cgi-bin/aw_cam?cmd=OSA:85:1&res=1
	応答	OSA:85:[Data]	-	ON				
	要求	QSA:85	1	ON				
	応答	OSA:85:[Data]	-	ON				
COLOR CORRECT TABLE	制御	OSL:6E:[Data]	0	A	cam	OSL:6E:[Data]	OSL:6E:[Data]	http://192.168.0.10/cgi-bin/aw_cam?cmd=OSL:6E:1&res=1
	応答	OSL:6E:[Data]	-	B				
	要求	QSL:6E	1	B				
	応答	OSL:6E:[Data]	-	B				
MATRIX(R-G)_N	制御	OSD:2F:[Data]	00h	-31	cam	OSD:2F:[Data]	OSD:2F:0x[Data]	http://192.168.0.10/cgi-bin/aw_cam?cmd=OSD:2F:1F&res=1
	応答	OSD:2F:[Data]	-	0				
	要求	QSD:2F	1Fh	0				
	応答	OSD:2F:[Data]	-	+31				

コマンド名	種別	コマンド	Data値	設定値	コマンドタイプ	更新通知	camdata.html	使用例・備考
MATRIX (R-G)_P	制御	OSL:6F:[Data]	00h	-31	cam	OSL:6F:[Data]	OSL:6F:0x[Data]	http://192.168.0.10/cgi-bin/aw_cam?cmd=OSL:6F:1F&res=1
	応答	OSL:6F:[Data]	-	0				
	要求	QSL:6F	1Fh	-				
	応答	OSL:6F:[Data]	3Eh	+31				
MATRIX (R-B)_N	制御	OSD:30:[Data]	00h	-31	cam	OSD:30:[Data]	OSD:30:0x[Data]	http://192.168.0.10/cgi-bin/aw_cam?cmd=OSD:30:1F&res=1
	応答	OSD:30:[Data]	-	0				
	要求	QSD:30	1Fh	-				
	応答	OSD:30:[Data]	3Eh	+31				
MATRIX (R-B)_P	制御	OSL:70:[Data]	00h	-31	cam	OSL:70:[Data]	OSL:70:0x[Data]	http://192.168.0.10/cgi-bin/aw_cam?cmd=OSL:70:1F&res=1
	応答	OSL:70:[Data]	-	0				
	要求	QSL:70	1Fh	-				
	応答	OSL:70:[Data]	3Eh	+31				
MATRIX (G-R)_N	制御	OSD:31:[Data]	00h	-31	cam	OSD:31:[Data]	OSD:31:0x[Data]	http://192.168.0.10/cgi-bin/aw_cam?cmd=OSD:31:1F&res=1
	応答	OSD:31:[Data]	-	0				
	要求	QSD:31	1Fh	-				
	応答	OSD:31:[Data]	3Eh	+31				
MATRIX (G-R)_P	制御	OSL:71:[Data]	00h	-31	cam	OSL:71:[Data]	OSL:71:0x[Data]	http://192.168.0.10/cgi-bin/aw_cam?cmd=OSL:71:1F&res=1
	応答	OSL:71:[Data]	-	0				
	要求	QSL:71	1Fh	-				
	応答	OSL:71:[Data]	3Eh	+31				
MATRIX (G-B)_N	制御	OSD:32:[Data]	00h	-31	cam	OSD:32:[Data]	OSD:32:0x[Data]	http://192.168.0.10/cgi-bin/aw_cam?cmd=OSD:32:1F&res=1
	応答	OSD:32:[Data]	-	0				
	要求	QSD:32	1Fh	-				
	応答	OSD:32:[Data]	3Eh	+31				
MATRIX (G-B)_P	制御	OSL:72:[Data]	00h	-31	cam	OSL:72:[Data]	OSL:72:0x[Data]	http://192.168.0.10/cgi-bin/aw_cam?cmd=OSL:72:1F&res=1
	応答	OSL:72:[Data]	-	0				
	要求	QSL:72	1Fh	-				
	応答	OSL:72:[Data]	3Eh	+31				
MATRIX (B-R)_N	制御	OSD:33:[Data]	00h	-31	cam	OSD:33:[Data]	OSD:33:0x[Data]	http://192.168.0.10/cgi-bin/aw_cam?cmd=OSD:33:1F&res=1
	応答	OSD:33:[Data]	-	0				
	要求	QSD:33	1Fh	-				
	応答	OSD:33:[Data]	3Eh	+31				
MATRIX (B-R)_P	制御	OSL:73:[Data]	00h	-31	cam	OSL:73:[Data]	OSL:73:0x[Data]	http://192.168.0.10/cgi-bin/aw_cam?cmd=OSL:73:1F&res=1
	応答	OSL:73:[Data]	-	0				
	要求	QSL:73	1Fh	-				
	応答	OSL:73:[Data]	3Eh	+31				
MATRIX (B-G)_N	制御	OSD:34:[Data]	00h	-31	cam	OSD:34:[Data]	OSD:34:0x[Data]	http://192.168.0.10/cgi-bin/aw_cam?cmd=OSD:34:1F&res=1
	応答	OSD:34:[Data]	-	0				
	要求	QSD:34	1Fh	-				
	応答	OSD:34:[Data]	3Eh	+31				
MATRIX (B-G)_P	制御	OSL:74:[Data]	00h	-31	cam	OSL:74:[Data]	OSL:74:0x[Data]	http://192.168.0.10/cgi-bin/aw_cam?cmd=OSL:74:1F&res=1
	応答	OSL:74:[Data]	-	0				
	要求	QSL:74	1Fh	-				
	応答	OSL:74:[Data]	3Eh	+31				

コマンド名	種別	コマンド	Data値	設定値	コマンドタイプ	更新通知	camdata.html	使用例・備考
REQUEST MATRIX (R/G/B/CY/MG/YE)	制御	-	[Data1]R-X 701h-8FFh [Data2]R-Y 701h-8FFh [Data3]G-X 701h-8FFh	[Data1]R-X -255~255 [Data2]R-Y -255~255 [Data3]G-X -255~255	cam	-	-	http://192.168.0.10/cgi-bin/aw_cam?cmd=QSL:B2&res=1
	応答	-	[Data4]G-Y 701h-8FFh [Data5]B-X 701h-8FFh [Data6]B-Y 701h-8FFh	[Data4]G-Y -255~255 [Data5]B-X -255~255 [Data6]B-Y -255~255				
	要求	QSL:B2	[Data7]CY-X 701h-8FFh [Data8]CY-Y 701h-8FFh [Data9]MG-X 701h-8FFh	[Data7]CY-X -255~255 [Data8]CY-Y -255~255 [Data9]MG-X -255~255				
	応答	OSL:B2:[Data1]:[Data2] [Data3]:[Data4]:[Data5] :[Data6]:[Data7]:[Data8] :[Data9]:[Data10]:[Data11]:[Data12]	[Data10]MG-Y 701h-8FFh [Data11]YL-X 701h-8FFh [Data12]YL-Y 701h-8FFh	[Data10]MG-Y -255~255 [Data11]YL-X -255~255 [Data12]YL-Y -255~255				
COLOR CORRECTION G SATURATION	制御	OSD:8E:[Data]	01h	-127	cam	OSD:8E:[Data]	OSD:8E:0x[Data]	http://192.168.0.10/cgi-bin/aw_cam?cmd=OSD:8E:80&res=1
	応答	OSD:8E:[Data]	-	-				
	要求	QSD:8E	80h	0				
	応答	OSD:8E:[Data]	FEh	126				
COLOR CORRECTION G_CY SATURATION	制御	OSD:90:[Data]	01h	-127	cam	OSD:90:[Data]	OSD:90:0x[Data]	http://192.168.0.10/cgi-bin/aw_cam?cmd=OSD:90:80&res=1
	応答	OSD:90:[Data]	-	-				
	要求	QSD:90	80h	0				
	応答	OSD:90:[Data]	FEh	126				
COLOR CORRECTION CY SATURATION	制御	OSD:92:[Data]	01h	-127	cam	OSD:92:[Data]	OSD:92:0x[Data]	http://192.168.0.10/cgi-bin/aw_cam?cmd=OSD:92:80&res=1
	応答	OSD:92:[Data]	-	-				
	要求	QSD:92	80h	0				
	応答	OSD:92:[Data]	FEh	126				
COLOR CORRECTION CY_B SATURATION	制御	OSD:94:[Data]	01h	-127	cam	OSD:94:[Data]	OSD:94:0x[Data]	http://192.168.0.10/cgi-bin/aw_cam?cmd=OSD:94:80&res=1
	応答	OSD:94:[Data]	-	-				
	要求	QSD:94	80h	0				
	応答	OSD:94:[Data]	FEh	126				
COLOR CORRECTION B SATURATION	制御	OSD:96:[Data]	01h	-127	cam	OSD:96:[Data]	OSD:96:0x[Data]	http://192.168.0.10/cgi-bin/aw_cam?cmd=OSD:96:80&res=1
	応答	OSD:96:[Data]	-	-				
	要求	QSD:96	80h	0				
	応答	OSD:96:[Data]	FEh	126				
COLOR CORRECTION B_MG SATURATION	制御	OSD:80:[Data]	01h	-127	cam	OSD:80:[Data]	OSD:80:0x[Data]	http://192.168.0.10/cgi-bin/aw_cam?cmd=OSD:80:80&res=1
	応答	OSD:80:[Data]	-	-				
	要求	QSD:80	80h	0				
	応答	OSD:80:[Data]	FEh	126				

コマンド名	種別	コマンド	Data値	設定値	コマンドタイプ	更新通知	camdata.html	使用例・備考
COLOR CORRECTION MG SATURATION	制御	OSD:82:[Data]	01h	-127	cam	OSD:82:[Data]	OSD:82:0x[Data]	http://192.168.0.10/cgi-bin/aw_cam?cmd=OSD:82:80&res=1
	応答	OSD:82:[Data]	-	-				
	要求	QSD:82	80h	0				
	応答	OSD:82:[Data]	FEh	126				
COLOR CORRECTION MG_R SATURATION	制御	OSD:84:[Data]	01h	-127	cam	OSD:84:[Data]	OSD:84:0x[Data]	http://192.168.0.10/cgi-bin/aw_cam?cmd=OSD:84:80&res=1
	応答	OSD:84:[Data]	-	-				
	要求	QSD:84	80h	0				
	応答	OSD:84:[Data]	FEh	126				
COLOR CORRECTION R SATURATION	制御	OSD:86:[Data]	01h	-127	cam	OSD:86:[Data]	OSD:86:0x[Data]	http://192.168.0.10/cgi-bin/aw_cam?cmd=OSD:86:80&res=1
	応答	OSD:86:[Data]	-	-				
	要求	QSD:86	80h	0				
	応答	OSD:86:[Data]	FEh	126				
COLOR CORRECTION R_YE SATURATION	制御	OSD:88:[Data]	01h	-127	cam	OSD:88:[Data]	OSD:88:0x[Data]	http://192.168.0.10/cgi-bin/aw_cam?cmd=OSD:88:80&res=1
	応答	OSD:88:[Data]	-	-				
	要求	QSD:88	80h	0				
	応答	OSD:88:[Data]	FEh	126				
COLOR CORRECTION YE SATURATION	制御	OSD:8A:[Data]	01h	-127	cam	OSD:8A:[Data]	OSD:8A:0x[Data]	http://192.168.0.10/cgi-bin/aw_cam?cmd=OSD:8A:80&res=1
	応答	OSD:8A:[Data]	-	-				
	要求	QSD:8A	80h	0				
	応答	OSD:8A:[Data]	FEh	126				
COLOR CORRECTION YE_G SATURATION	制御	OSD:8C:[Data]	01h	-127	cam	OSD:8C:[Data]	OSD:8C:0x[Data]	http://192.168.0.10/cgi-bin/aw_cam?cmd=OSD:8C:80&res=1
	応答	OSD:8C:[Data]	-	-				
	要求	QSD:8C	80h	0				
	応答	OSD:8C:[Data]	FEh	126				
COLOR CORRECTION G PHASE	制御	OSD:8F:[Data]	01h	-127	cam	OSD:8F:[Data]	OSD:8F:0x[Data]	http://192.168.0.10/cgi-bin/aw_cam?cmd=OSD:8F:80&res=1
	応答	OSD:8F:[Data]	-	-				
	要求	QSD:8F	80h	0				
	応答	OSD:8F:[Data]	FEh	126				
COLOR CORRECTION G_CY PHASE	制御	OSD:91:[Data]	01h	-127	cam	OSD:91:[Data]	OSD:91:0x[Data]	http://192.168.0.10/cgi-bin/aw_cam?cmd=OSD:91:80&res=1
	応答	OSD:91:[Data]	-	-				
	要求	QSD:91	80h	0				
	応答	OSD:91:[Data]	FEh	126				
COLOR CORRECTION CY PHASE	制御	OSD:93:[Data]	01h	-127	cam	OSD:93:[Data]	OSD:93:0x[Data]	http://192.168.0.10/cgi-bin/aw_cam?cmd=OSD:93:80&res=1
	応答	OSD:93:[Data]	-	-				
	要求	QSD:93	80h	0				
	応答	OSD:93:[Data]	FEh	126				
COLOR CORRECTION CY_B PHASE	制御	OSD:95:[Data]	01h	-127	cam	OSD:95:[Data]	OSD:95:0x[Data]	http://192.168.0.10/cgi-bin/aw_cam?cmd=OSD:95:80&res=1
	応答	OSD:95:[Data]	-	-				
	要求	QSD:95	80h	0				
	応答	OSD:95:[Data]	FEh	126				

コマンド名	種別	コマンド	Data値	設定値	コマンドタイプ	更新通知	camdata.html	使用例・備考
COLOR CORRECTION B PHASE	制御	OSD:97:[Data]	01h	-127	cam	OSD:97:[Data]	OSD:97:0x[Data]	http://192.168.0.10/cgi-bin/aw_cam?cmd=OSD:97:80&res=1
	応答	OSD:97:[Data]	-	-				
	要求	QSD:97	80h	0				
	応答	OSD:97:[Data]	FEh	126				
COLOR CORRECTION B_MG PHASE	制御	OSD:81:[Data]	01h	-127	cam	OSD:81:[Data]	OSD:81:0x[Data]	http://192.168.0.10/cgi-bin/aw_cam?cmd=OSD:81:80&res=1
	応答	OSD:81:[Data]	-	-				
	要求	QSD:81	80h	0				
	応答	OSD:81:[Data]	FEh	126				
COLOR CORRECTION MG PHASE	制御	OSD:83:[Data]	01h	-127	cam	OSD:83:[Data]	OSD:83:0x[Data]	http://192.168.0.10/cgi-bin/aw_cam?cmd=OSD:83:80&res=1
	応答	OSD:83:[Data]	-	-				
	要求	QSD:83	80h	0				
	応答	OSD:83:[Data]	FEh	126				
COLOR CORRECTION MG_R PHASE	制御	OSD:85:[Data]	01h	-127	cam	OSD:85:[Data]	OSD:85:0x[Data]	http://192.168.0.10/cgi-bin/aw_cam?cmd=OSD:85:80&res=1
	応答	OSD:85:[Data]	-	-				
	要求	QSD:85	80h	0				
	応答	OSD:85:[Data]	FEh	126				
COLOR CORRECTION R PHASE	制御	OSD:87:[Data]	01h	-127	cam	OSD:87:[Data]	OSD:87:0x[Data]	http://192.168.0.10/cgi-bin/aw_cam?cmd=OSD:87:80&res=1
	応答	OSD:87:[Data]	-	-				
	要求	QSD:87	80h	0				
	応答	OSD:87:[Data]	FEh	126				
COLOR CORRECTION R_YE PHASE	制御	OSD:89:[Data]	01h	-127	cam	OSD:89:[Data]	OSD:89:0x[Data]	http://192.168.0.10/cgi-bin/aw_cam?cmd=OSD:89:80&res=1
	応答	OSD:89:[Data]	-	-				
	要求	QSD:89	80h	0				
	応答	OSD:89:[Data]	FEh	126				
COLOR CORRECTION YE PHASE	制御	OSD:8B:[Data]	01h	-127	cam	OSD:8B:[Data]	OSD:8B:0x[Data]	http://192.168.0.10/cgi-bin/aw_cam?cmd=OSD:8B:80&res=1
	応答	OSD:8B:[Data]	-	-				
	要求	QSD:8B	80h	0				
	応答	OSD:8B:[Data]	FEh	126				
COLOR CORRECTION YE_G PHASE	制御	OSD:8D:[Data]	01h	-127	cam	OSD:8D:[Data]	OSD:8D:0x[Data]	http://192.168.0.10/cgi-bin/aw_cam?cmd=OSD:8D:80&res=1
	応答	OSD:8D:[Data]	-	-				
	要求	QSD:8D	80h	0				
	応答	OSD:8D:[Data]	FEh	126				
DNR	制御	OSD:3A:[Data]	00	OFF	cam	OSD:3A:[Data]	OSD:3A:0x[Data]	http://192.168.0.10/cgi-bin/aw_cam?cmd=OSD:3A:01&res=1
	応答	OSD:3A:[Data]	01	ON				
	要求	QSD:3A	02	ON				
	応答	OSD:3A:[Data]						
DNR LEVEL	制御	OSG:B5:[Data]	1	1	cam	OSG:B5:[Data]	OSG:B5:[Data]	http://192.168.0.10/cgi-bin/aw_cam?cmd=OSG:B5:1&res=1
	応答	OSG:B5:[Data]	-	-				
	要求	QSG:B5	5	5				
	応答	OSG:B5:[Data]						
HDR PAINT HLG MODE	制御	OSI:39:[Data]	0	FIX	cam	OSI:39:[Data]	OSI:39:[Data]	http://192.168.0.10/cgi-bin/aw_cam?cmd=OSI:39:1&res=1
	応答	OSI:39:[Data]	1	VAR				
	要求	QSI:39						
	応答	OSI:39:[Data]						

コマンド名	種別	コマンド	Data値	設定値	コマンドタイプ	更新通知	camdata.html	使用例・備考
HDR PAINT SDR CONVERT MODE	制御	OSI:3A:[Data]	0 1	FIX VAR	cam	OSI:3A:[Data]	OSI:3A:[Data]	http://192.168.0.10/cgi-bin/aw_cam?cmd=OSI:3A:1&res=1
	応答	OSI:3A:[Data]						
	要求	QSI:3A						
	応答	OSI:3A:[Data]						
HDR PAINT BLACK GAMMA	制御	OSI:3C:[Data]	0 1	OFF ON	cam	OSI:3C:[Data]	OSI:3C:[Data]	http://192.168.0.10/cgi-bin/aw_cam?cmd=OSI:3C:1&res=1
	応答	OSI:3C:[Data]						
	要求	QSI:3C						
	応答	OSI:3C:[Data]						
HDR PAINT MASTER BLACK GAMMA	制御	OSI:3D:[Data]	60h - 80h - A0h	-32 - 0 - +32	cam	OSI:3D:[Data]	OSI:3D:0x[Data]	http://192.168.0.10/cgi-bin/aw_cam?cmd=OSI:3D:81&res=1
	応答	OSI:3D:[Data]						
	要求	QSI:3D						
	応答	OSI:3D:[Data]						
HDR PAINT R BLACK GAMMA	制御	OSI:3E:[Data]	60h - 80h - A0h	-32 - 0 - +32	cam	OSI:3E:[Data]	OSI:3E:0x[Data]	http://192.168.0.10/cgi-bin/aw_cam?cmd=OSI:3E:81&res=1
	応答	OSI:3E:[Data]						
	要求	QSI:3E						
	応答	OSI:3E:[Data]						
HDR PAINT B BRACK GAMMA	制御	OSI:3F:[Data]	60h - 80h - A0h	-32 - 0 - +32	cam	OSI:3F:[Data]	OSI:3F:0x[Data]	http://192.168.0.10/cgi-bin/aw_cam?cmd=OSI:3F:81&res=1
	応答	OSI:3F:[Data]						
	要求	QSI:3F						
	応答	OSI:3F:[Data]						
HDR PAINT KNEE	制御	OSI:40:[Data]	0 1	OFF ON	cam	OSI:40:[Data]	OSI:40:[Data]	http://192.168.0.10/cgi-bin/aw_cam?cmd=OSI:40:1&res=1
	応答	OSI:40:[Data]						
	要求	QSI:40						
	応答	OSI:40:[Data]						
HDR PAINT KNEE POINT	制御	OSI:41:[Data]	30h - 80h - D0h	60.00% - 80.00% - 100.00%	cam	OSI:41:[Data]	OSI:41:0x[Data]	http://192.168.0.10/cgi-bin/aw_cam?cmd=OSI:41:81&res=1 1step=0.25%
	応答	OSI:41:[Data]						
	要求	QSI:41						
	応答	OSI:41:[Data]						
HDR PAINT KNEE SLOPE	制御	OSI:42:[Data]	00h - C7h	0 - 199	cam	OSI:42:[Data]	OSI:42:0x[Data]	http://192.168.0.10/cgi-bin/aw_cam?cmd=OSI:42:01&res=1
	応答	OSI:42:[Data]						
	要求	QSI:42						
	応答	OSI:42:[Data]						
HDR PAINT SDR CONVERT GAIN	制御	OSI:43:[Data]	74h - 7Bh - 80h	-12dB - -5dB - 0dB	cam	OSI:43:[Data]	OSI:43:0x[Data]	http://192.168.0.10/cgi-bin/aw_cam?cmd=OSI:43:74&res=1
	応答	OSI:43:[Data]						
	要求	QSI:43						
	応答	OSI:43:[Data]						
HDR PAINT SDR CONVERT POINT	制御	OSL:88:[Data]	00h - 64h	0 - 100	cam	OSL:88:[Data]	OSL:88:0x[Data]	http://192.168.0.10/cgi-bin/aw_cam?cmd=OSL:88:01&res=1
	応答	OSL:88:[Data]						
	要求	QSL:88						
	応答	OSL:88:[Data]						
HDR PAINT SDR CONVERT SLOPE	制御	OSL:89:[Data]	00h - 7Fh	0 - 127	cam	OSL:89:[Data]	OSL:89:0x[Data]	http://192.168.0.10/cgi-bin/aw_cam?cmd=OSL:89:01&res=1
	応答	OSL:89:[Data]						
	要求	QSL:89						
	応答	OSL:89:[Data]						
HDR PAINT SDR CONVERT BLACK OFFSET	制御	OSL:8A:[Data]	1Ch - 80h - E4h	-100 - 0 - +100	cam	OSL:8A:[Data]	OSL:8A:0x[Data]	http://192.168.0.10/cgi-bin/aw_cam?cmd=OSL:8A:81&res=1
	応答	OSL:8A:[Data]						
	要求	QSL:8A						
	応答	OSL:8A:[Data]						

LENS

コマンド名	種別	コマンド	Data値	設定値	コマンドタイプ	更新通知	camdata.html	使用例・備考
FOCUS MODE	制御	OAF:[Data]	0 1	MANUAL AUTO	cam	OAF:[Data]	OAF:[Data]	http://192.168.0.10/cgi-bin/aw_cam?cmd=OAF:0&res=1
	応答	OAF:[Data]						
	要求	QAF						
	応答	OAF:[Data]						
FOCUS MODE	制御	#D1 [Data]	0 1	MANUAL AUTO	ptz	d1 [Data]	d1 [Data]	http://192.168.0.10/cgi-bin/aw_ptz?cmd=%23D10&res=1
	応答	d1 [Data]						
	要求	#D1						
	応答	d1 [Data]						
AF SENSITIVITY	制御	OSJ:D8:[Data]	0 1	NORMAL STABLE	cam	OSJ:D8:[Data]	OSJ:D8:[Data]	http://192.168.0.10/cgi-bin/aw_cam?cmd=OSJ:D8:1&res=1
	応答	OSJ:D8:[Data]						
	要求	QSJ:D8						
	応答	OSJ:D8:[Data]						
ZOOM MODE DIGITAL ZOOM	制御	OSE:70:[Data]	0 1	DISABLE ENABLE	cam	OSE:70:[Data]	OSE:70:[Data]	http://192.168.0.10/cgi-bin/aw_cam?cmd=OSE:70:1&res=1 [ZOOM MODE] -Opt Zoom OSE:70:0 OSD:B3:0 -i Zoom OSE:70:0 OSD:B3:1 -D Zoom OSE:70:1 OSD:B3:0
	応答	OSE:70:[Data]						
	要求	QSE:70						
ZOOM MODE I. ZOOM	制御	OSD:B3:[Data]	0 1	DISABLE ENABLE	cam	OSD:B3:[Data]	OSD:B3:[Data]	http://192.168.0.10/cgi-bin/aw_cam?cmd=OSD:B3:0&res=1
	応答	OSD:B3:[Data]						
	要求	QSD:B3						
	応答	OSD:B3:[Data]						
MAX DIGITAL ZOOM	制御	OSE:7A:[Data]	02 - 10	x2 - x10	cam	OSE:7A:[Data]	OSE:7A:[Data]	http://192.168.0.10/cgi-bin/aw_cam?cmd=OSE:7A:10&res=1
	応答	OSE:7A:[Data]						
	要求	QSE:7A						
	応答	OSE:7A:[Data]						
DIGITAL EXTENDER	制御	OSJ:4E:[Data]	0 1 2	OFF x1.4 x2.0	cam	OSJ:4E:[Data]	OSJ:4E:[Data]	http://192.168.0.10/cgi-bin/aw_cam?cmd=OSJ:4E:1&res=1
	応答	OSJ:4E:[Data]						
	要求	QSJ:4E						
	応答	OSJ:4E:[Data]						
O. I. S.	制御	OSL:8B:[Data]	0 1	OFF ON	cam	OSL:8B:[Data]	OSL:8B:[Data]	http://192.168.0.10/cgi-bin/aw_cam?cmd=OSL:8B:1&res=1
	応答	OSL:8B:[Data]						
	要求	QSL:8B						
	応答	OSL:8B:[Data]						
O. I. S. MODE	制御	OSL:8C:[Data]	1 2 3 4	O. I. S (STABLE) O. I. S (PAN/TILT) HYBRID (STABLE) HYBRID (PAN/TILT)	cam	OSL:8C:[Data]	OSL:8C:[Data]	http://192.168.0.10/cgi-bin/aw_cam?cmd=OSL:8C:1&res=1
	応答	OSL:8C:[Data]						
	要求	QSL:8C						
	応答	OSL:8C:[Data]						
O. I. S. MODE	制御	OIS:[Data]	0 1 2 3 4	OFF O. I. S (STABLE) O. I. S (PAN/TILT) HYBRID (STABLE) HYBRID (PAN/TILT)	cam	OIS:[Data]	OIS:[Data]	http://192.168.0.10/cgi-bin/aw_cam?cmd=OIS:0&res=1
	応答	OIS:[Data]						
	要求	QIS						
	応答	OIS:[Data]						
ND FILTER	制御	OFT:[Data]	0 1 2 3	THROUGH 1/4 1/16 1/64	cam	OFT:[Data]	OFT:[Data]	http://192.168.0.10/cgi-bin/aw_cam?cmd=OFT:0&res=1
	応答	OFT:[Data]						
	要求	QFT						
	応答	OFT:[Data]						
ZOOM SCALE	制御	-	000h - 3E7h	0 - 999	cam	-	-	http://192.168.0.10/cgi-bin/aw_cam?cmd=QSJ:3D&res=1
	応答	-						
	要求	QSJ:3D						
	応答	OSJ:3D:[Data]						

コマンド名	種別	コマンド	Data値	設定値	コマンドタイプ	更新通知	camdata.html	使用例・備考
DIGITAL ZOOM MAGNIFICATION	制御	OSE:76:[Data]	0100	x1.00	cam	OSE:76:[Data]	-	http://192.168.0.10/cgi-bin/aw_cam?cmd=OSE:76:0100&res=1
	応答	OSE:76:[Data]	-	-				
	要求	QSE:76	9999	x99.99				
	応答	OSE:76:[Data]						
ZOOM SPEED CONTROL	制御	#Z[Data]	01	WIDE MAX. SPEED	ptz	-	-	http://192.168.0.10/cgi-bin/aw_ptz?cmd=%23Z50&res=1
	応答	zS[Data]	49	WIDE MIN. SPEED				
	要求	-	50	ZOOM STOP				
	応答	-	51	TELE MIN. SPEED				
ZOOM POSITION CONTROL	制御	#AXZ[Data]	555h	WIDE	ptz	-	axz[Data]	http://192.168.0.10/cgi-bin/aw_ptz?cmd=%23AXZ555&res=1
	応答	axz[Data]	-	-				
	要求	#AXZ	FFFh	TELE				
	応答	axz[Data]						
FOCUS SPEED CONTROL	制御	#F[Data]	01	NEAR MAX. SPEED	ptz	-	-	http://192.168.0.10/cgi-bin/aw_ptz?cmd=%23F50&res=1
	応答	fS[Data]	49	NEAR MIN. SPEED				
	要求	-	50	STOP				
	応答	-	51	FAR MIN. SPEED				
FOCUS POSITION CONTROL	制御	#AXF[Data]	555h	NEAR	ptz	-	axf[Data]	http://192.168.0.10/cgi-bin/aw_ptz?cmd=%23AXF555&res=1
	応答	axf[Data]	-	-				
	要求	#AXF	FFFh	FAR				
	応答	axf[Data]						
PUSH AUTO FOCUS	制御	OSE:69:[Data]	1	PUSH AUTO	cam	-	-	http://192.168.0.10/cgi-bin/aw_cam?cmd=OSE:69:1&res=1
	応答	OSE:69:[Data]						
	要求	-						
	応答	-						
TOUCH AF	制御	OSJ:28:[Data1]:[Data2]	[Data1]	[Data1] H POS.	cam	-	-	http://192.168.0.10/cgi-bin/aw_cam?cmd=OSJ:28:32:32&res=1
	応答	OSJ:28:[Data1]:[Data2]	00h	0%				
	要求	-	64h	100%				
	応答	-	[Data2]	[Data2] V POS.				
IRIS CONTROL	制御	#AXI[Data]	555h	IRIS CLOSE	ptz	-	axi[Data]	http://192.168.0.10/cgi-bin/aw_ptz?cmd=%23AXI555&res=1
	応答	axi[Data]	-	-				
	要求	#AXI	FFFh	IRIS OPEN				
	応答	axi[Data]						
IRIS CONTROL	制御	#I[Data]	01	IRIS CLOSE	ptz	-	-	http://192.168.0.10/cgi-bin/aw_ptz?cmd=%23I50&res=1
	応答	iC[Data]	-	-				
	要求	#I	99	IRIS OPEN				
	応答	iC[Data]						
IRIS CONTROL	制御	ORV:[Data]	000h	IRIS CLOSE	cam	ORV:[Data]	-	http://192.168.0.10/cgi-bin/aw_cam?cmd=ORV:000&res=1
	応答	ORV:[Data]	-	-				
	要求	QRV	3FFh	IRIS OPEN				
	応答	ORV:[Data]						
IRIS FOLLOW	制御	-	00h	IRIS CLOSE	cam	OSD:4F:[Data]	OSD:4F:[Data]	http://192.168.0.10/cgi-bin/aw_cam?cmd=QSD:4F&res=1
	応答	-	-	-				
	要求	QSD:4F	FFh	IRIS OPEN				
	応答	OSD:4F:[Data]						

コマンド名	種別	コマンド	Data値	設定値	コマンドタイプ	更新通知	camdata.html	使用例・備考
LENS POSITION INFORMATION	制御	-	[Data1] 555h	[Data1]ZOOM POSITION WIDE	ptz	IPI [Data1] [Data2] [Data3]	-	http://192.168.0.10/cgi-bin/aw_ptz?cmd=%23LPI&res=1
	応答	-	FFFh [Data2] 555h	[Data2]FOCUS POSITION NEAR				
	要求	#LPI	FFFh [Data3] 555h	FAR [Data3]IRIS POSITION CLOSE				
	応答	IPI [Data1] [Data2] [Data3]	- FFFh	- OPEN				
LENS POSITION INFORMATION CONTROL	制御	#LPC [Data]	0 1	OFF ON	ptz	IPC [Data]	-	http://192.168.0.10/cgi-bin/aw_ptz?cmd=%23LPC1&res=1
	応答	IPC [Data]						
	要求	#LPC						
	応答	IPC [Data]						
REQUEST IRIS F NO.	制御	-	0Eh	F1.4	cam	OIF: [Data]	OIF: [Data]	http://192.168.0.10/cgi-bin/aw_cam?cmd=QIF&res=1
	応答	-	A0h	F16				
	要求	QIF	-	-				
	応答	OIF: [Data]	FFh	CLOSE				
REQUEST ZOOM POSITION	制御	-	555h	WIDE	ptz	-	-	http://192.168.0.10/cgi-bin/aw_ptz?cmd=%23GZ&res=1
	応答	-	FFFh	TELE				
	要求	#GZ	"----	@POWER OFF				
	応答	gz [Data]	"----	@POWER OFF				
REQUEST FOCUS POSITION	制御	-	555h	NEAR	ptz	-	-	http://192.168.0.10/cgi-bin/aw_ptz?cmd=%23GF&res=1
	応答	-	FFFh	FAR				
	要求	#GF	"----	@POWER OFF				
	応答	gf [Data]	"----	@POWER OFF				
REQUEST IRIS POSITION	制御	-	[Data1] 555h	[Data1] CLOSE	ptz	-	-	http://192.168.0.10/cgi-bin/aw_ptz?cmd=%23GI&res=1
	応答	-	FFFh	OPEN				
	要求	#GI	"----	@POWER OFF				
	応答	gi [Data1] [Data2]	[Data2] 0 1	[Data2] MANUAL IRIS AUTO IRIS				
FOCUS GUIDE	制御	OSL:C3: [Data]	0 1	OFF ON	cam	-	-	http://192.168.0.10/cgi-bin/aw_cam?cmd=OSL:C3:1&res=1
	応答	OSL:C3: [Data]						
	要求	QSL:C3						
	応答	OSL:C3: [Data]						
FOCUS GUIDE	制御	OSL:C4: [Data1]: [Data2]	[Data1] 00h	[Data1] H POS. 0%	cam	-	-	http://192.168.0.10/cgi-bin/aw_cam?cmd=OSL:C4:32:32&res=1 有効範囲はH:17%~83%, V:10%~90%
	応答	OSL:C4: [Data1]: [Data2]	- 64h	- 100%				
	要求	QSL:C4	[Data2] 00h	[Data2] V POS. 0%				
	応答	OSL:C4: [Data1]: [Data2]	- 64h	- 100%				

コマンド名	種別	コマンド	Data値	設定値	コマンドタイプ	更新通知	camdata.html	使用例・備考
FOCUS GUIDE	制御	-	7Bh	-5 (NEAR)	cam	-	-	http://192.168.0.10/cgi-bin/aw_cam?cmd=QSL:C5&res=1
	応答	-	80h	0 (IN FOCUS)				
	要求	QSL:C5	85h	5 (FAR)				
	応答	OSL:C5:[Data]	FEh FFh	FOCUS GUIDE OFF NOT MEASURABLE				
FOCUS GUIDE	制御	-	62h	-30 (NEAR)	cam	-	-	http://192.168.0.10/cgi-bin/aw_cam?cmd=QSL:C6&res=1
	応答	-	80h	0 (IN FOCUS)				
	要求	QSL:C6	9Eh	30 (FAR)				
	応答	OSL:C6:[Data]	FEh FFh	FOCUS GUIDE OFF NOT MEASURABLE				

MONITOR DISPLAY

コマンド名	種別	コマンド	Data値	設定値	コマンドタイプ	更新通知	camdata.html	使用例・備考
WFM MODE	制御	OSL:8D:[Data]	0	OFF	cam	OSL:8D:[Data]	-	http://192.168.0.10/cgi-bin/aw_cam?cmd=OSL:8D:1&res=1
	応答	OSL:8D:[Data]	1	ON(Y)				
	要求	QSL:8D	2	ON(Y/Pb/Pr)				
	応答	OSL:8D:[Data]						
WFM POSITION	制御	OSL:8E:[Data]	0	UR	cam	OSL:8E:[Data]	-	http://192.168.0.10/cgi-bin/aw_cam?cmd=OSL:8E:1&res=1
	応答	OSL:8E:[Data]	1	BR				
	要求	QSL:8E	2	BL				
	応答	OSL:8E:[Data]	3	UL				
STATUS INDICATOR RETURN SELECT	制御	OSL:B3:[Data]	0	OFF	cam	OSL:B3:[Data]	OSL:B3:[Data]	http://192.168.0.10/cgi-bin/aw_cam?cmd=OSL:B3:0&res=1
	応答	OSL:B3:[Data]	1	ON				
	要求	QSL:B3						
	応答	OSL:B3:[Data]						
STATUS INDICATOR STATUS(AUTO)	制御	OSA:88:[Data]	0	OFF	cam	OSA:88:[Data]	OSA:88:[Data]	http://192.168.0.10/cgi-bin/aw_cam?cmd=OSA:88:0&res=1
	応答	OSA:88:[Data]	1	ON				
	要求	QSA:88						
	応答	OSA:88:[Data]						
LEVEL GAUGE	制御	OSL:03:[Data]	0	OFF	cam	OSL:03:[Data]	-	http://192.168.0.10/cgi-bin/aw_cam?cmd=OSL:03:1&res=1
	応答	OSL:03:[Data]	1	ON				
	要求	QSL:03						
	応答	OSL:03:[Data]						
LEVEL GAUGE REQUEST INCLINATION	制御	-	[Data1]	[Data1]	cam	-	-	http://192.168.0.10/cgi-bin/aw_cam?cmd=QSL:AF&res=1
			1Dh	-9.9° (Left Down)				
			-	-				
	応答	-	[Data2]	[Data2]				
			1Dh	-9.9° (Right Down)				
			-	-				
	要求	QSL:AF	[Data3]	[Data3]				
			1Dh	-9.9° (Front Down)				
			-	-				
	応答	OSL:AF:[Data1]:[Data2]:[Data3]:[Data4]	[Data4]	[Data4]				
			1Dh	-9.9° (Back Down)				
			-	-				
			80h	0.0°				
			E3h	9.9° (Back Up)				

TRACKING DATA OUTPUT

コマンド名	種別	コマンド	Data値	設定値	コマンドタイプ	更新通知	camdata.html	使用例・備考
TRACKING DATA OUTPUT SERIAL	制御	OSJ:54:[Data]	0 1	OFF ON	cam	OSJ:54:[Data]	OSJ:54:[Data]	http://192.168.0.10/cgi-bin/aw_cam?cmd=OSJ:54:0&res=1
	応答	OSJ:54:[Data]						
	要求	QSJ:54						
	応答	OSJ:54:[Data]						
TRACKING DATA OUTPUT IP	制御	OSJ:55:[Data]	0 1	OFF ON	cam	OSJ:55:[Data]	OSJ:55:[Data]	http://192.168.0.10/cgi-bin/aw_cam?cmd=OSJ:55:0&res=1
	応答	OSJ:55:[Data]						
	要求	QSJ:55						
	応答	OSJ:55:[Data]						
TRACKING DATA OUTPUT INVERT PAN/TILT AXIS	制御	OSJ:C1:[Data]	0 1	OFF ON	cam	OSJ:C1:[Data]	OSJ:C1:[Data]	http://192.168.0.10/cgi-bin/aw_cam?cmd=OSJ:C1:0&res=1
	応答	OSJ:C1:[Data]						
	要求	QSJ:C1						
	応答	OSJ:C1:[Data]						
TRACKING DATA OUTPUT CAMERA ID	制御	OSJ:F4:[Data]	0x00 - 0xFF	0x00 - 0xFF	cam	OSJ:F4:[Data]	OSJ:F4:0x[Data]	http://192.168.0.10/cgi-bin/aw_cam?cmd=OSJ:F4:00&res=1
	応答	OSJ:F4:[Data]						
	要求	QSJ:F4						
	応答	OSJ:F4:[Data]						

CROP

コマンド名	種別	コマンド	Data値	設定値	コマンドタイプ	更新通知	camdata.html	使用例・備考
UHD CROP	制御	OSJ:2E:[Data]	0	OFF	cam	OSJ:2E:[Data]	OSJ:2E:[Data]	http://192.168.0.10/cgi-bin/aw_cam?cmd=OSJ:2E:0&res=1
	応答	OSJ:2E:[Data]	1	CROP (1080)				
	要求	QSJ:2E	2	CROP (720)				
	応答	OSJ:2E:[Data]						
CROP ZOOM	制御	OSJ:92:[Data]	0	OFF	cam	OSJ:92:[Data]	OSJ:92:[Data]	http://192.168.0.10/cgi-bin/aw_cam?cmd=OSJ:92:0&res=1
	応答	OSJ:92:[Data]	1	ON				
	要求	QSJ:92						
	応答	OSJ:92:[Data]						
CROP AF	制御	OSJ:91:[Data]	0	OFF	cam	OSJ:91:[Data]	OSJ:91:[Data]	http://192.168.0.10/cgi-bin/aw_cam?cmd=OSJ:91:0&res=1
	応答	OSJ:91:[Data]	1	ON				
	要求	QSJ:91						
	応答	OSJ:91:[Data]						
CROP 3G SDI1 OUT	制御	OSI:32:[Data]	0	FULL	cam	OSI:32:[Data]	OSI:32:[Data]	http://192.168.0.10/cgi-bin/aw_cam?cmd=OSI:32:0&res=1
	応答	OSI:32:[Data]	1	CROP				
	要求	QSI:32						
	応答	OSI:32:[Data]						
CROP NDI OUT	制御	OSJ:93:[Data]	0	FULL	cam	OSJ:93:[Data]	OSJ:93:[Data]	http://192.168.0.10/cgi-bin/aw_cam?cmd=OSJ:93:0&res=1
	応答	OSJ:93:[Data]	1	CROP				
	要求	QSJ:93						
	応答	OSJ:93:[Data]						
CROP IP(H.264/H.265) OUT1	制御	OSI:33:[Data]	0	FULL	cam	OSI:33:[Data]	OSI:33:[Data]	http://192.168.0.10/cgi-bin/aw_cam?cmd=OSI:33:0&res=1
	応答	OSI:33:[Data]	1	CROP				
	要求	QSI:33						
	応答	OSI:33:[Data]						
CROP IP(H.264/H.265) OUT2	制御	OSJ:94:[Data]	0	FULL	cam	OSJ:94:[Data]	OSJ:94:[Data]	http://192.168.0.10/cgi-bin/aw_cam?cmd=OSJ:94:0&res=1
	応答	OSJ:94:[Data]	1	CROP				
	要求	QSJ:94						
	応答	OSJ:94:[Data]						
CROP MARKER	制御	OSI:1A:[Data1]	0	OFF	cam	OSI:1A:[Data1]	OSI:1A:[Data1]	http://192.168.0.10/cgi-bin/aw_cam?cmd=OSI:1A:0&res=1
	1		YL					
	2		G					
	3		MG					
	4		YL+G					
	5		YL+MG					
	6		G+MG					
7		YL+G+MG						
CROP OUT	制御	OSI:16:[Data1]	1	YL	cam	OSI:16:[Data1]	OSI:16:[Data1]	http://192.168.0.10/cgi-bin/aw_cam?cmd=OSI:16:1&res=1
	応答	OSI:16:[Data1]	2	G				
	要求	QSI:16	3	MG				
	応答	OSI:16:[Data1]						
CROP ADJUST	制御	OSI:17:[Data1]	1	YL	cam	OSI:17:[Data1]	OSI:17:[Data1]	http://192.168.0.10/cgi-bin/aw_cam?cmd=OSI:17:1&res=1
	応答	OSI:17:[Data1]	2	G				
	要求	QSI:17	3	MG				
	応答	OSI:17:[Data1]						
CROP H POSITION	制御	OSJ:AF:[Data]	000h	0	cam	OSJ:AF:[Data]	OSJ:AF:0x[Data]	http://192.168.0.10/cgi-bin/aw_cam?cmd=OSJ:AF:000&res=1 [Data]:偶数のみ
	応答	OSJ:AF:[Data]	-	-				
	要求	QSJ:AF	C00h	3072				
	応答	OSJ:AF:[Data]						
CROP H POSITION(YL)	制御	OSJ:2F:[Data]	000h	0	cam	OSJ:2F:[Data]	OSJ:2F:0x[Data]	http://192.168.0.10/cgi-bin/aw_cam?cmd=OSJ:2F:000&res=1 [Data]:偶数のみ
	応答	OSJ:2F:[Data]	-	-				
	要求	QSJ:2F	C00h	3072				
	応答	OSJ:2F:[Data]						
CROP H POSITION(G)	制御	OSJ:31:[Data]	000h	0	cam	OSJ:31:[Data]	OSJ:31:0x[Data]	http://192.168.0.10/cgi-bin/aw_cam?cmd=OSJ:31:000&res=1 [Data]:偶数のみ
	応答	OSJ:31:[Data]	-	-				
	要求	QSJ:31	C00h	3072				
	応答	OSJ:31:[Data]						

コマンド名	種別	コマンド	Data値	設定値	コマンドタイプ	更新通知	camdata.html	使用例・備考
CROP H POSITION(MG)	制御	OSJ:33:[Data]	000h	0	cam	OSJ:33:[Data]	OSJ:33:0x[Data]	http://192.168.0.10/cgi-bin/aw_cam?cmd=OSJ:33:000&res=1 [Data]:偶数のみ
	応答	OSJ:33:[Data]	-	-				
	要求	QSJ:33	C00h	3072				
	応答	OSJ:33:[Data]	-	-				
CROP V POSITION	制御	OSJ:B0:[Data]	000h	0	cam	OSJ:B0:[Data]	OSJ:B0:0x[Data]	http://192.168.0.10/cgi-bin/aw_cam?cmd=OSJ:B0:000&res=1
	応答	OSJ:B0:[Data]	-	-				
	要求	QSJ:B0	6C0h	1728				
	応答	OSJ:B0:[Data]	-	-				
CROP V POSITION(YL)	制御	OSJ:30:[Data]	000h	0	cam	OSJ:30:[Data]	OSJ:30:0x[Data]	http://192.168.0.10/cgi-bin/aw_cam?cmd=OSJ:30:000&res=1
	応答	OSJ:30:[Data]	-	-				
	要求	QSJ:30	6C0h	1728				
	応答	OSJ:30:[Data]	-	-				
CROP V POSITION(G)	制御	OSJ:32:[Data]	000h	0	cam	OSJ:32:[Data]	OSJ:32:0x[Data]	http://192.168.0.10/cgi-bin/aw_cam?cmd=OSJ:32:000&res=1
	応答	OSJ:32:[Data]	-	-				
	要求	QSJ:32	6C0h	1728				
	応答	OSJ:32:[Data]	-	-				
CROP V POSITION(MG)	制御	OSJ:34:[Data]	000h	0	cam	OSJ:34:[Data]	OSJ:34:0x[Data]	http://192.168.0.10/cgi-bin/aw_cam?cmd=OSJ:34:000&res=1
	応答	OSJ:34:[Data]	-	-				
	要求	QSJ:34	6C0h	1728				
	応答	OSJ:34:[Data]	-	-				
CROP ZOOM RATIO	制御	OSJ:B1:[Data]	02EE0h	120.00%	cam	OSJ:B1:[Data]	OSJ:B1:0x[Data]	http://192.168.0.10/cgi-bin/aw_cam?cmd=OSJ:B1:02EE0&res=1
	応答	OSJ:B1:[Data]	-	-				
	要求	QSJ:B1	0C350h	500.00%				
	応答	OSJ:B1:[Data]	-	-				
CROP ZOOM RATIO(YL)	制御	OSJ:98:[Data]	02EE0h	120.00%	cam	OSJ:98:[Data]	OSJ:98:0x[Data]	http://192.168.0.10/cgi-bin/aw_cam?cmd=OSJ:98:02EE0&res=1
	応答	OSJ:98:[Data]	-	-				
	要求	QSJ:98	0C350h	500.00%				
	応答	OSJ:98:[Data]	-	-				
CROP ZOOM RATIO(G)	制御	OSJ:99:[Data]	02EE0h	120.00%	cam	OSJ:99:[Data]	OSJ:99:0x[Data]	http://192.168.0.10/cgi-bin/aw_cam?cmd=OSJ:99:02EE0&res=1
	応答	OSJ:99:[Data]	-	-				
	要求	QSJ:99	0C350h	500.00%				
	応答	OSJ:99:[Data]	-	-				
CROP ZOOM RATIO(MG)	制御	OSJ:9A:[Data]	02EE0h	120.00%	cam	OSJ:9A:[Data]	OSJ:9A:0x[Data]	http://192.168.0.10/cgi-bin/aw_cam?cmd=OSJ:9A:02EE0&res=1
	応答	OSJ:9A:[Data]	-	-				
	要求	QSJ:9A	0C350h	500.00%				
	応答	OSJ:9A:[Data]	-	-				
CROP ZOOM RATIO(YL, G, MG)	制御	OSJ:9B:[Data1]:[Data2]:[Data3]	[Data1] 02EE0h - 0C350h	[Data1] Zoom Ratio (YL) 120.00% - 500.00%	cam	-	-	http://192.168.0.10/cgi-bin/aw_cam?cmd=OSJ:9B:02EE0:02EE0:02EE0&res=1
	応答	OSJ:9B:[Data1]:[Data2]:[Data3]	[Data2] 02EE0h - 0C350h	[Data2] Zoom Ratio (G) 120.00% - 500.00%				
	要求	QSJ:9B						
	応答	OSJ:9B:[Data1]:[Data2]:[Data3]	[Data3] 02EE0h - 0C350h	[Data3] Zoom Ratio (MG) 120.00% - 500.00%				
CROP ZOOM RATIO SPEED CONTROL	制御	OSJ:9C:[Data]	01	Wide Max. Speed	cam	-	-	http://192.168.0.10/cgi-bin/aw_cam?cmd=OSJ:9C:50&res=1
	応答	OSJ:9C:[Data]	49	Wide Min. Speed				
	要求	---	50 51	Stop Tele Min. Speed				
	応答	---	- 99	- Tele Max. Speed				

コマンド名	種別	コマンド	Data値	設定値	コマンドタイプ	更新通知	camdata.html	使用例・備考
CROP ZOOM RATIO SPEED CONTROL (YL)	制御	OSJ:9D:[Data]	01 -	Wide Max. Speed -	cam	-	-	http://192.168.0.10/cgi-bin/aw_cam?cmd=OSJ:9D:50&res=1
	応答	OSJ:9D:[Data]	49 50	Wide Min. Speed Stop				
	要求	---	51 -	Tele Min. Speed -				
	応答	---	99	Tele Max. Speed				
CROP ZOOM RATIO SPEED CONTROL (G)	制御	OSJ:9E:[Data]	01 -	Wide Max. Speed -	cam	-	-	http://192.168.0.10/cgi-bin/aw_cam?cmd=OSJ:9E:50&res=1
	応答	OSJ:9E:[Data]	49 50	Wide Min. Speed Stop				
	要求	---	51 -	Tele Min. Speed -				
	応答	---	99	Tele Max. Speed				
CROP ZOOM RATIO SPEED CONTROL (MG)	制御	OSJ:9F:[Data]	01 -	Wide Max. Speed -	cam	-	-	http://192.168.0.10/cgi-bin/aw_cam?cmd=OSJ:9F:50&res=1
	応答	OSJ:9F:[Data]	49 50	Wide Min. Speed Stop				
	要求	---	51 -	Tele Min. Speed -				
	応答	---	99	Tele Max. Speed				
CROP ZOOM RATIO SPEED CONTROL (YL, G, MG)	制御	OSJ:A1:[Data1]:[Data2]:[Data3]	[Data1]	[Data1] (YL)	cam	-	-	http://192.168.0.10/cgi-bin/aw_cam?cmd=OSJ:A1:50:50:50&res=1
			01	Wide Max. Speed				
			49	Wide Min. Speed				
			50	Stop				
	応答	OSJ:A1:[Data1]:[Data2]:[Data3]	51	Tele Min. Speed				
			99	Tele Max. Speed				
			[Data2]	[Data2] (G)				
			01	Wide Max. Speed				
要求	---	49	Wide Min. Speed					
		50	Stop					
		51	Tele Min. Speed					
		99	Tele Max. Speed					
応答	---	[Data3]	[Data3] (MG)					
		01	Wide Max. Speed					
		49	Wide Min. Speed					
		50	Stop					
		51	Tele Min. Speed					
		99	Tele Max. Speed					

コマンド名	種別	コマンド	Data値	設定値	コマンドタイプ	更新通知	camdata.html	使用例・備考
GET CROP H/V POSITION (YL, G, MG)	制御	OSJ:60:[Data1]:[Data2] :[Data3]:[Data4]:[Data5]:[Data6]	[Data1] 000h - C00h [Data2] 000h -	[Data1] H POS (YL) 0 - 3072 [Data2] V POS (YL) 0 -	cam	-	-	http://192.168.0.10/cgi-bin/aw_cam?cmd=OSJ:60:000:000:000:000:000&res=1 [Data1], [Data3], [Data5]:偶数のみ
	応答	OSJ:60:[Data1]:[Data2] :[Data3]:[Data4]:[Data5]:[Data6]	6C0 [Data3] 000h - C00h [Data4] 000h -	1728 [Data3] H POS (G) 0 - 3072 [Data4] V POS (G) 0 -				
	要求	QSJ:60	- 6C0 [Data5] 000h -	1728 [Data5] H POS (MG) 0 -				
	応答	OSJ:60:[Data1]:[Data2] :[Data3]:[Data4]:[Data5]:[Data6]	C00h [Data6] 000h - 6C0h	3072 [Data6] V POS (MG) 0 - 3072				
CROP H/V POSITION SPEED CONTROL	制御	OSI:15:[Data1]:[Data2]	[Data1] 01 - 50 -	[Data1] LEFT MAX. SPEED - STOP -	cam	-	-	http://192.168.0.10/cgi-bin/aw_cam?cmd=OSI:15:50:50&res=1
	応答	OSI:15:[Data1]:[Data2]	99	RIGHT MAX. SPEED				
	要求	---	[Data2] 01 - 50 -	[Data2] DOWN MAX. SPEED - STOP -				
	応答	---	99	UP MAX. SPEED				
CROP H/V POSITION SPEED CONTROL (YL)	制御	OSJ:5D:[Data1]:[Data2]	[Data1] 01 - 50 -	[Data1] LEFT MAX. SPEED - STOP -	cam	-	-	http://192.168.0.10/cgi-bin/aw_cam?cmd=OSJ:5D:50:50&res=1
	応答	OSJ:5D:[Data1]:[Data2]	99	RIGHT MAX. SPEED				
	要求	---	[Data2] 01 - 50 -	[Data2] DOWN MAX. SPEED - STOP -				
	応答	---	99	UP MAX. SPEED				

コマンド名	種別	コマンド	Data値	設定値	コマンドタイプ	更新通知	camdata.html	使用例・備考
CROP H/V POSITION SPEED CONTROL (G)	制御	OSJ:5E:[Data1]:[Data2]	[Data1] 01 - 50	[Data1] LEFT MAX. SPEED - STOP	cam	-	-	http://192.168.0.10/cgi-bin/aw_cam?cmd=OSJ:5E:50:50&res=1
	応答	OSJ:5E:[Data1]:[Data2]	- 99	- RIGHT MAX. SPEED				
	要求	---	[Data2] 01 - 50	[Data2] DOWN MAX. SPEED - STOP				
	応答	---	- 99	- UP MAX. SPEED				
CROP H/V POSITION SPEED CONTROL (MG)	制御	OSJ:5F:[Data1]:[Data2]	[Data1] 01 - 50	[Data1] LEFT MAX. SPEED - STOP	cam	-	-	http://192.168.0.10/cgi-bin/aw_cam?cmd=OSJ:5F:50:50&res=1
	応答	OSJ:5F:[Data1]:[Data2]	- 99	- RIGHT MAX. SPEED				
	要求	---	[Data2] 01 - 50	[Data2] DOWN MAX. SPEED - STOP				
	応答	---	- 99	- UP MAX. SPEED				
CROP H/V POSITION SPEED CONTROL (YL/G/MG)	制御	OSJ:A0:[Data1]:[Data2] :[Data3]:[Data4]:[Data5]:[Data6]	[Data1] 01 50 99 [Data2] 01 50 99	[Data1] (YL) LEFT MAX. SPEED STOP RIGHT MAX. SPEED [Data2] (YL) DOWN MAX. SPEED STOP UP MAX. SPEED	cam	-	-	http://192.168.0.10/cgi-bin/aw_cam?cmd=OSJ:A0:50:50:50:50:50&res=1
	応答	OSJ:A0:[Data1]:[Data2] :[Data3]:[Data4]:[Data5]:[Data6]	[Data3] 01 50 99	[Data3] (G) LEFT MAX. SPEED STOP RIGHT MAX. SPEED				
	要求	---	[Data4] 01 50 99	[Data4] (G) DOWN MAX. SPEED STOP UP MAX. SPEED				
	応答	---	[Data5] 01 50 99 [Data6] 01 50 99	[Data5] (MG) LEFT MAX. SPEED STOP RIGHT MAX. SPEED [Data6] (MG) DOWN MAX. SPEED STOP UP MAX. SPEED				

コマンド名	種別	コマンド	Data値	設定値	コマンドタイプ	更新通知	camdata.html	使用例・備考
CROP POSITION / CROP ZOOM POSITION SPEED CONTROL (YL/G/MG)	制御	OSJ:C2:[Data1]:[Data2] :[Data3]:[Data4]:[Data5]: [Data6]:[Data7]:[Data8]: [Data9]	[Data1] 01 - 50 - 99 [Data2] 01 - 50 - 99 [Data3] 01 - 50 - 99	[Data1]YL H CROP POSITION LEFT MAX. SPD - STOP - RIGHT MAX. SPD [Data2]YL V CROP POSITION DOWN MAX. SPD - STOP - UP MAX. SPD [Data3]G H CROP POSITION LEFT MAX. SPD - STOP - RIGHT MAX. SPD	cam	-	-	http://192.168.0.10/cgi-bin/aw_cam?cmd=OSJ:C2:01:01:50:50:99:99:30:50:70&res=1
	応答	OSJ:C2:[Data1]:[Data2] :[Data3]:[Data4]:[Data5]: [Data6]:[Data7]:[Data8]: [Data9]	[Data4] 01 - 50 - 99 [Data5] 01 - 50 - 99 [Data6] 01 - 50 - 99	[Data4]G V CROP POSITION DOWN MAX. SPD - STOP - UP MAX. SPD [Data5]MG H CROP POSITION LEFT MAX. SPD - STOP - RIGHT MAX. SPD [Data6]MG V CROP POSITION DOWN MAX. SPD - STOP - UP MAX. SPD				
	要求	-	[Data7] 01 - 50 - 99 [Data8] 01 - 50 - 99	[Data7] YL CROP ZOOM POSITION WIDE MAX. SPD - STOP - TELE MAX. SPD [Data8] G CROP ZOOM POSITION WIDE MAX. SPD - STOP - TELE MAX. SPD				
	応答	-	[Data9] 01 - 50 - 99	[Data9]MG CROP ZOOM POSITION WIDE MAX. SPD - STOP - TELE MAX. SPD				
REQUEST CROP POSITION / CROP ZOOM POSITION	制御	-	[Data1] 000h - C00h [Data2] 000h - 6C0h	[Data1] H POS (YL) 0 - 3072 [Data2] V POS (YL) 0 - 1728	cam	-	-	http://192.168.0.10/cgi-bin/aw_cam?cmd=QSJ:C3&res=1
	応答	-	[Data3] 000h - C00h [Data4] 000h - 6C0h	[Data3] H POS (G) 0 - 3072 [Data4] V POS (G) 0 - 1728				
	要求	QSJ:C3	[Data5] 000h - C00h [Data6] 000h - 6C0h [Data7] 02EE0h - 0C350h [Data8] 02EE0h - 0C350h [Data9] 02EE0h - 0C350h	[Data5] H POS (MG) 0 - 3072 [Data6] V POS (MG) 0 - 1728 [Data7] ZOOM RATIO (YL) 120.00% - 500.00%				
	応答	OSJ:C3:[Data1]:[Data2] :[Data3]:[Data4]:[Data5]: [Data6]:[Data7]:[Data8]: [Data9]	[Data8] 02EE0h - 0C350h [Data9] 02EE0h - 0C350h	[Data8] ZOOM RATIO (G) 120.00% - 500.00% [Data9] ZOOM RATIO (MG) 120.00% - 500.00%				

PANTILT

コマンド名	種別	コマンド	Data値	設定値	コマンドタイプ	更新通知	camdata.html	使用例・備考
INSTALL POSITION	制御	#INS[Data]	0 1	DESKTOP HANGING	ptz	iNS[Data]	iNS[Data]	http://192.168.0.10/cgi-bin/aw_ptz?cmd=%23INS1&res=1
	応答	iNS[Data]						
	要求	#INS						
	応答	iNS[Data]						
SMART PICTURE FLIP	制御	#SPF[Data]	0 1	OFF AUTO	ptz	sPF[Data]	-	http://192.168.0.10/cgi-bin/aw_ptz?cmd=%23SPF1&res=1
	応答	sPF[Data]						
	要求	#SPF						
	応答	sPF[Data]						
FLIP STATUS	制御	-	0 1	NORMAL FLIP	cam	-	-	http://192.168.0.10/cgi-bin/aw_cam?cmd=QFS&res=1
	応答	-						
	要求	QFS						
	応答	OFS:[Data]						
FLIP DETECT ANGLE	制御	#FDA[Data]	3Ch - 78h	60deg - 120deg	ptz	fDA[Data]	-	http://192.168.0.10/cgi-bin/aw_ptz?cmd=%23FDA5A&res=1
	応答	fDA[Data]						
	要求	#FDA						
	応答	fDA[Data]						
P/T SPEED MODE	制御	OSJ:2D:[Data]	0 1 2	NORMAL (60deg/s) FAST1 (90deg/s) FAST2 (180deg/s)	cam	OSJ:2D:[Data]	OSJ:2D:[Data]	http://192.168.0.10/cgi-bin/aw_cam?cmd=OSJ:2D:0&res=1
	応答	OSJ:2D:[Data]						
	要求	QSJ:2D						
	応答	OSJ:2D:[Data]						
P/T ACCELERATION	制御	OSJ:A2:[Data]	0 1	MANUAL AUTO	cam	OSJ:A2:[Data]	OSJ:A2:[Data]	http://192.168.0.10/cgi-bin/aw_cam?cmd=OSJ:A2:0&res=1
	応答	OSJ:A2:[Data]						
	要求	QSJ:A2						
	応答	OSJ:A2:[Data]						
P/T ACCELERATION RISE S-CURVE	制御	OSJ:A3:[Data]	00h - 1E	0 - 30	cam	OSJ:A3:[Data]	OSJ:A3:0x[Data]	http://192.168.0.10/cgi-bin/aw_cam?cmd=OSJ:A3:00&res=1
	応答	OSJ:A3:[Data]						
	要求	QSJ:A3						
	応答	OSJ:A3:[Data]						
P/T ACCELERATION FALL S-CURVE	制御	OSJ:A4:[Data]	00h - 1E	0 - 30	cam	OSJ:A4:[Data]	OSJ:A4:0x[Data]	http://192.168.0.10/cgi-bin/aw_cam?cmd=OSJ:A4:00&res=1
	応答	OSJ:A4:[Data]						
	要求	QSJ:A4						
	応答	OSJ:A4:[Data]						
P/T ACCELERATION RISE ACCELERATION	制御	OSJ:A5:[Data]	01h - FFh	1 - 255	cam	OSJ:A5:[Data]	OSJ:A5:0x[Data]	http://192.168.0.10/cgi-bin/aw_cam?cmd=OSJ:A5:01&res=1
	応答	OSJ:A5:[Data]						
	要求	QSJ:A5						
	応答	OSJ:A5:[Data]						
P/T ACCELERATION FALL ACCELERATION	制御	OSJ:A6:[Data]	01h - FFh	1 - 255	cam	OSJ:A6:[Data]	OSJ:A6:0x[Data]	http://192.168.0.10/cgi-bin/aw_cam?cmd=OSJ:A6:01&res=1
	応答	OSJ:A6:[Data]						
	要求	QSJ:A6						
	応答	OSJ:A6:[Data]						
SPEED WITH ZOOM POSITION	制御	#SWZ[Data]	0 1	OFF ON	ptz	sWZ[Data]	sWZ[Data]	http://192.168.0.10/cgi-bin/aw_ptz?cmd=%23SWZ1&res=1
	応答	sWZ[Data]						
	要求	#SWZ						
	応答	sWZ[Data]						
FOCUS ADJUST WITH PTZ.	制御	OAZ:[Data]	0 1	OFF ON	cam	OAZ:[Data]	OAZ:[Data]	http://192.168.0.10/cgi-bin/aw_cam?cmd=OAZ:0&res=1
	応答	OAZ:[Data]						
	要求	QAZ						
	応答	OAZ:[Data]						
PRIVACY MODE	制御	OSJ:A7:[Data]	0 1	OFF ON	cam	OSJ:A7:[Data]	OSJ:A7:[Data]	http://192.168.0.10/cgi-bin/aw_cam?cmd=OSJ:A7:0&res=1
	応答	OSJ:A7:[Data]						
	要求	QSJ:A7						
	応答	OSJ:A7:[Data]						
POWER ON POSITION	制御	OSJ:45:[Data]	0 1 2 3	NONE STANDBY HOME PRESET	cam	OSJ:45:[Data]	OSJ:45:[Data]	http://192.168.0.10/cgi-bin/aw_cam?cmd=OSJ:45:1&res=1
	応答	OSJ:45:[Data]						
	要求	QSJ:45						
	応答	OSJ:45:[Data]						

コマンド名	種別	コマンド	Data値	設定値	コマンドタイプ	更新通知	camdata.html	使用例・備考
PRESET NUMBER	制御	OSJ:46:[Data]	00	PRESET001	cam	OSJ:46:[Data]	OSJ:46:[Data]	http://192.168.0.10/cgi-bin/aw_cam?cmd=OSJ:46:00&res=1
	応答	OSJ:46:[Data]	-	-				
	要求	QSJ:46	99	PRESET100				
	応答	OSJ:46:[Data]						
PAN SPEED CONTROL	制御	#P[Data]	01	LEFT MAX. SPEED	ptz	-	-	http://192.168.0.10/cgi-bin/aw_ptz?cmd=%23P50&res=1
	応答	pS[Data]	50	STOP				
	要求	-	-	-				
	応答	-	99	RIGHT MAX. SPEED				
TILT SPEED CONTROL	制御	#T[Data]	01	DOWN MAX. SPEED	ptz	-	-	http://192.168.0.10/cgi-bin/aw_ptz?cmd=%23T50&res=1
	応答	tS[Data]	50	STOP				
	要求	-	-	-				
	応答	-	99	UP MAX. SPEED				
P/T SPEED CONTROL	制御	#PTS[Data1][Data2]	[Data1] 01	[Data1] LEFT MAX. SPEED	ptz	-	-	http://192.168.0.10/cgi-bin/aw_ptz?cmd=%23PTS5050&res=1
	応答	pTS[Data1][Data2]	- 50	- STOP				
	要求	-	[Data2] 01	[Data2] DOWN MAX. SPEED				
	応答	-	- 50	- STOP				
P/T ABSOLUTE POSITION CONTROL	制御	#APC[Data1][Data2]	[Data1] 0000h	[Data1]PAN POSITION CCW LIMIT	ptz	aPC[Data1][Data2]	aPC[Data1][Data2]	http://192.168.0.10/cgi-bin/aw_ptz?cmd=%23APC80008000&res=1 Pan : 2D09 (-175deg) - D2F5 (+175deg) Tilt : 8E38 (-30deg) - 1C71 (+210deg)
	応答	aPC[Data1][Data2]	- 8000h	- CENTER				
	要求	#APC	FFFFh [Data2] 0000h	[Data2]TILT POSITION UP LIMIT				
	応答	aPC[Data1][Data2]	- 8000h	- CENTER				
			FFFFh	DOWN LIMIT				

コマンド名	種別	コマンド	Data値	設定値	コマンドタイプ	更新通知	camdata.html	使用例・備考
P/T RELATIVE POSITION CONTROL	制御	#RPC[Data1][Data2]	[Data1] 0000h - 8000h - FFFFh	[Data1]PAN POSITION CCW LIMIT - CENTER - CW LIMIT	ptz	-	-	http://192.168.0.10/cgi-bin/aw_ptz?cmd=%23RPC80008000&res=1
	応答	rPC[Data1][Data2]	[Data2] 0000h - 8000h - FFFFh	[Data2]TILT POSITION UP LIMIT - CENTER - DOWN LIMIT				
	要求	-	[Data3] 0000h - 8000h - FFFFh	[Data3]PRESET SPEED 1 - 30				
	応答	-	[Data4] 0 1 2	[Data4]PRESET SPEED TABLE SLOW FAST FAST				
P/T ABSOLUTE POSITION CONTROL WITH SPEED	制御	#APS[Data1][Data2][Data3][Data4]	[Data1] 0000h - 8000h - FFFFh	[Data1]PAN POSITION CCW LIMIT - CENTER - CW LIMIT	ptz	-	-	http://192.168.0.10/cgi-bin/aw_ptz?cmd=%23APS800080001D0&res=1 Pan : 2D09(-175deg) - D2F5(+175deg) Tilt : 8E38(-30deg) - 1C71(+210deg)
	応答	aPS[Data1][Data2][Data3][Data4]	[Data2] 0000h - 8000h - FFFFh	[Data2]TILT POSITION UP LIMIT - CENTER - DOWN LIMIT				
	要求	-	[Data3] 00h - 1Dh	[Data3]PRESET SPEED 1 - 30				
	応答	-	[Data4] 0 1 2	[Data4]PRESET SPEED TABLE SLOW FAST FAST				
P/T RELATIVE POSITION CONTROL WITH SPEED	制御	#RPS[Data1][Data2][Data3][Data4]	[Data1] 0000h - 8000h - FFFFh	[Data1]PAN POSITION CCW LIMIT - CENTER - CW LIMIT	ptz	-	-	http://192.168.0.10/cgi-bin/aw_ptz?cmd=%23RPS800080001D0&res=1
	応答	rPS[Data1][Data2][Data3][Data4]	[Data2] 0000h - 8000h - FFFFh	[Data2]TILT POSITION UP LIMIT - CENTER - DOWN LIMIT				
	要求	-	[Data3] 00h - 1Dh	[Data3]PRESET SPEED 1 - 30				
	応答	-	[Data4] 0 1 2	[Data4]PRESET SPEED TABLE SLOW MID FAST				

コマンド名	種別	コマンド	Data値	設定値	コマンドタイプ	更新通知	camdata.html	使用例・備考
LIMITATION CONTROL	制御	#LC[Data1][Data2]	[Data1] 1	[Data1] TILT UP	ptz	IC[Data1][Data2]	IC1[Data2] IC2[Data2] IC3[Data2] IC4[Data2]	http://192.168.0.10/cgi-bin/aw_ptz?cmd=%23LC1&res=1
	応答	IC[Data1][Data2]	2	TILT DOWN				
	要求	#LC[Data1]	3	PAN LEFT				
	応答	IC[Data1][Data2]	4 [Data2] 0 1	[Data2] RELEASE SET				
LIMITATION CONTROL (TOGGLE)	制御	#L[Data]	Controller - > P/T 1	TILT UP	ptz	-	-	http://192.168.0.10/cgi-bin/aw_ptz?cmd=%23L1&res=1
	応答	l[Data]	2	TILT DOWN				
	要求	-	3	PAN LEFT				
	応答	-	4 P/T -> Controller 0 1	RELEASE SET				

便利コマンド

コマンド名	種別	コマンド	Data値	設定値	コマンドタイプ	更新通知	camdata.html	使用例・備考
GET GAIN/COLOR TEMPERATURE/SHUTTER/ND	制御	-	[Data1] 02h - 14h 80h	[Data1] (GAIN) -6dB - 12dB AGC ON	ptz	-	-	http://192.168.0.10/cgi-bin/aw_ptz?cmd=%23PTG&res=1
	応答	-	[Data2] 00000h - 3A98h [Data3] 0h 1h 2h 3h	[Data2] (COLOR TEMP) OK - 15000K [Data3] (SHUTTER MODE) OFF STEP SYNCRO ELC				
	要求	#PTG	[Data4] 0001h - 2710 h [Data5] 00000h - 186A0h [Data6] 0 1 2 3	[Data4] (SHUTTER STEP) 1/1 - 1/10000 [Data5] (SHUTTER SYNCHRO) 0.0 [HZ] - 10000.0 [HZ] [Data6] (ND) THROUGH 1/4 ND 1/16 ND 1/64 ND				
	応答	pTG[Data1][Data2][Data3][Data4][Data5][Data6]						
GET PAN/TILT/ZOOM/FOCUS/IRIS	制御	-	[Data1] 0000h - 8000h - FFFFh	[Data1] (PAN) CCWLIMIT - CENTER - CWLIMIT	ptz	-	-	http://192.168.0.10/cgi-bin/aw_ptz?cmd=%23PTV&res=1
	応答	-	[Data2] 0000h - 8000h - FFFFh	[Data2] (TILT) UPLIMIT - CENTER - DOWNLIMIT				
	要求	#PTV	[Data3] 555h - FFFh [Data4] 555h - FFFh [Data5] 555h - FFFh	[Data3] (ZOOM) WIDE - TELE [Data4] (FOCUS) NEAR - FAR [Data5] (IRIS) CLOSE - OPEN				
	応答	pTV[Data1][Data2][Data3][Data4][Data5]						

コマンド名	種別	コマンド	Data値	設定値	コマンドタイプ	更新通知	camdata.html	使用例・備考
GET PAN/TILT/ZOOM/FOCUS/IRIS	制御	-	[Data1] 0000h - FFFFh	[Data1] (PAN) 0000h - FFFFh	ptz	-	-	http://192.168.0.10/cgi-bin/aw_ptz?cmd=%23PTD&res=1
	応答	-	[Data2] 0000h - FFFFh	[Data2] (TILT) 0000h - FFFFh				
	要求	#PTD	[Data3] 000h - 3E7h	[Data3] (ZOOM) 0 - 999				
	応答	pTD[Data1][Data2][Data3][Data4][Data5]	[Data4] 00h - 63h	[Data4] (FOCUS) 0 - 99				
			[Data5] 00h - FEh FFh	[Data5] (IRIS) F0.0 - F25.4 CLOSE				

PRESET

コマンド名	種別	コマンド	Data値	設定値	コマンドタイプ	更新通知	camdata.html	使用例・備考
PRESET PTZ SYNC MODE	制御	OSL:CE:[Data]	0 1	OFF ON	cam	OSL:CE:[Data]	OSL:CE:[Data]	http://192.168.0.10/cgi-bin/aw_cam?cmd=OSL:CE:1&res=1
	応答	OSL:CE:[Data]						
	要求	QSL:CE						
	応答	OSL:CE:[Data]						
PRESET SPEED UNIT	制御	OSJ:29:[Data]	0 1	SPEED TABLE TIME	cam	OSJ:29:[Data]	OSJ:29:[Data]	http://192.168.0.10/cgi-bin/aw_cam?cmd=OSJ:29:0&res=1
	応答	OSJ:29:[Data]						
	要求	QSJ:29						
	応答	OSJ:29:[Data]						
PRESET SPEED TABLE	制御	#PST[Data]	0 2	SLOW FAST	ptz	pST[Data]	pST[Data]	http://192.168.0.10/cgi-bin/aw_ptz?cmd=%23PST0&res=1
	応答	pST[Data]						
	要求	#PST						
	応答	pST[Data]						
PRESET SPEED	制御	#UPVS[Data]	000 250 - 999 001h - 063h	PRESET SPEED UNIT :SPEED 30 : MAX SPEED 1 : SLOW ~ 30 : FAST PRESET SPEED UNIT :TIME 1秒 ~ 99秒	ptz	uPVS[Data]	uPVS[Data]	http://192.168.0.10/cgi-bin/aw_ptz?cmd=%23UPVS250&res=1 Preset Speed Unit : Speed 001-275:1 276-301:2 302-327:3 328-353:4 354-379:5 380-404:6 405-430:7 431-456:8 457-482:9 483-508:10 509-534:11 535-559:12 560-585:13 586-611:14 612-637:15 638-663:16 664-689:17 690-714:18 715-740:19 741-766:20 767-792:21 793-818:22 819-844:23 845-869:24 870-895:25 896-921:26 922-947:27 948-973:28 974-998:29 999,000:30
	応答	uPVS[Data]						
	要求	#UPVS						
	要求	#UPVS						
	応答	uPVS[Data]						
	応答	uPVS[Data]						
PRESET ACCELERATION	制御	OSJ:A8:[Data]	0 1	MANUAL AUTO	cam	OSJ:A8:[Data]	OSJ:A8:[Data]	http://192.168.0.10/cgi-bin/aw_cam?cmd=OSJ:A8:0&res=1
	応答	OSJ:A8:[Data]						
	要求	QSJ:A8						
	応答	OSJ:A8:[Data]						
PRESET ACCELERATION RISE S-CURVE	制御	OSJ:A9:[Data]	00h - 1E	0 - 30	cam	OSJ:A9:[Data]	OSJ:A9:0x[Data]	http://192.168.0.10/cgi-bin/aw_cam?cmd=OSJ:A9:00&res=1
	応答	OSJ:A9:[Data]						
	要求	QSJ:A9						
	応答	OSJ:A9:[Data]						
PRESET ACCELERATION FALL S-CURVE	制御	OSJ:AA:[Data]	00h - 1E	0 - 30	cam	OSJ:AA:[Data]	OSJ:AA:0x[Data]	http://192.168.0.10/cgi-bin/aw_cam?cmd=OSJ:AA:00&res=1
	応答	OSJ:AA:[Data]						
	要求	QSJ:AA						
	応答	OSJ:AA:[Data]						

コマンド名	種別	コマンド	Data値	設定値	コマンドタイプ	更新通知	camdata.html	使用例・備考
PRESET ACCELERATION RISE ACCELERATION	制御	OSJ:AB:[Data]	01h	1	cam	OSJ:AB:[Data]	OSJ:AB:0x[Data]	http://192.168.0.10/cgi-bin/aw_cam?cmd=OSJ:AB:01&res=1
	応答	OSJ:AB:[Data]	-	-				
	要求	QSJ:AB	FFh	255				
	応答	OSJ:AB:[Data]						
PRESET ACCELERATION FALL ACCELERATION	制御	OSJ:AC:[Data]	01h	1	cam	OSJ:AC:[Data]	OSJ:AC:0x[Data]	http://192.168.0.10/cgi-bin/aw_cam?cmd=OSJ:AC:01&res=1
	応答	OSJ:AC:[Data]	-	-				
	要求	QSJ:AC	FFh	255				
	応答	OSJ:AC:[Data]						
PRESET ACCELERATION RISE RAMP TIME	制御	OSJ:AD:[Data]	01h	0.1s	cam	OSJ:AD:[Data]	OSJ:AD:0x[Data]	http://192.168.0.10/cgi-bin/aw_cam?cmd=OSJ:AD:01&res=1
	応答	OSJ:AD:[Data]	-	-				
	要求	QSJ:AD	64h	10.0s				
	応答	OSJ:AD:[Data]						
PRESET ACCELERATION FALL RAMP TIME	制御	OSJ:AE:[Data]	01h	0.1s	cam	OSJ:AE:[Data]	OSJ:AE:0x[Data]	http://192.168.0.10/cgi-bin/aw_cam?cmd=OSJ:AE:01&res=1
	応答	OSJ:AE:[Data]	-	-				
	要求	QSJ:AE	64h	10.0s				
	応答	OSJ:AE:[Data]						
PRESET SCOPE	制御	OSE:71:[Data]	0	MODE A	cam	OSE:71:[Data]	OSE:71:[Data]	http://192.168.0.10/cgi-bin/aw_cam?cmd=OSE:71:0&res=1
	応答	OSE:71:[Data]	1	MODE B				
	要求	QSE:71	2	MODE C				
	応答	OSE:71:[Data]						
PRESET DIGITAL EXTENDER	制御	OSE:7C:[Data]	0	OFF	cam	OSE:7C:[Data]	OSE:7C:[Data]	http://192.168.0.10/cgi-bin/aw_cam?cmd=OSE:7C:0&res=1
	応答	OSE:7C:[Data]	1	ON				
	要求	QSE:7C						
	応答	OSE:7C:[Data]						
PRESET CROP	制御	OSJ:2A:[Data]	0	OFF	cam	OSJ:2A:[Data]	OSJ:2A:[Data]	http://192.168.0.10/cgi-bin/aw_cam?cmd=OSJ:2A:0&res=1
	応答	OSJ:2A:[Data]	1	ON				
	要求	QSJ:2A						
	応答	OSJ:2A:[Data]						
PRESET THUMBNAIL UPDATE	制御	OSJ:2B:[Data]	0	OFF	cam	OSJ:2B:[Data]	OSJ:2B:[Data]	http://192.168.0.10/cgi-bin/aw_cam?cmd=OSJ:2B:0&res=1
	応答	OSJ:2B:[Data]	1	ON				
	要求	QSJ:2B						
	応答	OSJ:2B:[Data]						
PRESET NAME	制御	OSJ:2C:[Data]	0	RESET	cam	OSJ:2C:[Data]	OSJ:2C:[Data]	http://192.168.0.10/cgi-bin/aw_cam?cmd=OSJ:2C:0&res=1
	応答	OSJ:2C:[Data]	1	HOLD				
	要求	QSJ:2C						
	応答	OSJ:2C:[Data]						
PRESET IRIS	制御	OSJ:5B:[Data]	0	OFF	cam	OSJ:5B:[Data]	OSJ:5B:[Data]	http://192.168.0.10/cgi-bin/aw_cam?cmd=OSJ:5B:0&res=1
	応答	OSJ:5B:[Data]	1	ON				
	要求	QSJ:5B						
	応答	OSJ:5B:[Data]						
PRESET SHUTTER	制御	OSJ:D5:[Data]	0	OFF	cam	OSJ:D5:[Data]	OSJ:D5:[Data]	http://192.168.0.10/cgi-bin/aw_cam?cmd=OSJ:D5:0&res=1
	応答	OSJ:D5:[Data]	1	ON				
	要求	QSJ:D5						
	応答	OSJ:D5:[Data]						
PRESET ZOOM MODE	制御	OSE:7D:[Data]	0	MODE A	cam	OSE:7D:[Data]	OSE:7D:[Data]	http://192.168.0.10/cgi-bin/aw_cam?cmd=OSE:7D:0&res=1
	応答	OSE:7D:[Data]	1	MODE B				
	要求	QSE:7D						
	応答	OSE:7D:[Data]						
FREEZE DURING PRESET	制御	#PRF[Data]	0	OFF	ptz	pRF[Data]	pRF[Data]	http://192.168.0.10/cgi-bin/aw_ptz?cmd=%23PRF0&res=1
	応答	pRF[Data]	1	ON				
	要求	#PRF						
	応答	pRF[Data]						
RECALL PRESET MEMORY	制御	#R[Data]	00	PRESET001	ptz	-	-	http://192.168.0.10/cgi-bin/aw_ptz?cmd=%23R00&res=1
	応答	s[Data]	-	-				
	要求	-	99	PRESET100				
	応答	-						
SAVE PRESET MEMORY	制御	#M[Data]	00	PRESET001	ptz	-	-	http://192.168.0.10/cgi-bin/aw_ptz?cmd=%23M00&res=1
	応答	s[Data]	-	-				
	要求	-	99	PRESET100				
	応答	-						

コマンド名	種別	コマンド	Data値	設定値	コマンドタイプ	更新通知	camdata.html	使用例・備考
DELETE PRESET MEMORY	制御	#C[Data]	00	PRESET001	ptz	-	-	http://192.168.0.10/cgi-bin/aw_ptz?cmd=%23C00&res=1
	応答	s[Data]	-	-				
	要求	-	99	PRESET100				
	応答	-	-	-				
PRESET ENTRY CONFIRMATION	制御	-	[Data1] 00h - 02h	[Data1] MULTIPLE (EACH 40 PRESET NO)	ptz	pE[Data1][Data2]	pE00[Data2] pE01[Data2] pE02[Data2]	http://192.168.0.10/cgi-bin/aw_ptz?cmd=%23PE00&res=1
	応答	-	[Data2] 0000000000h - FFFFFFFFFh	[Data2]				
	要求	#PE[Data1]	(bit0) 0 1 (bit1) 0 1 -	PRESET NO. (Data1*40 +1) NO ENTRY ENTRY PRESET NO. (Data1*40 +2) NO ENTRY ENTRY -				
	応答	pE[Data1][Data2]	(39bit) 0 1	PRESET NO. (Data1*40 +40) NO ENTRY ENTRY				
REQUEST LATEST RECALL PRESET NO.	制御	-	00	PRESET001	ptz	s[Data]	s[Data]	http://192.168.0.10/cgi-bin/aw_ptz?cmd=%23S&res=1
	応答	-	-	-				
	要求	#S	99	PRESET100				
	応答	s[Data]	-	-				
PRESET COMPLETION NOTIFICATION	制御	-	00	PRESET001	ptz	q[Data]	-	シーケンスは6-4章を参照ください
	応答	q[Data]	-	-				
	要求	-	99	PRESET100				
	応答	-	-	-				
SAVE PRESET NAME	制御	OSJ:35:[Data1]:[Data2]	[Data1] 00	[Data1] PRESET001	cam	OSJ:35:[Data1]:[Data2]	-	http://192.168.0.10/cgi-bin/aw_cam?cmd=OSJ:35:00:xxxxxxxxxxxx&res=1
	応答	OSJ:35:[Data1]:[Data2]	-	-				
	要求	QSJ:35:[Data1]	99	PRESET100				
	応答	OSJ:35:[Data1]:[Data2]	[Data2] xxxxxxxxxxx xxx	PRESET NAME (FIXED 15 CHARACTORS)				
DELETE PRESET NAME (SINGLE)	制御	OSJ:36:[Data1]	00	PRESET001	cam	OSJ:36:[Data]	-	http://192.168.0.10/cgi-bin/aw_cam?cmd=OSJ:36:00&res=1
	応答	OSJ:36:[Data]	-	-				
	要求	-	99	PRESET100				
	応答	-	-	-				
DELETE PRESET NAME (ALL)	制御	OSJ:37	-	-	cam	OSJ:37	-	http://192.168.0.10/cgi-bin/aw_cam?cmd=OSJ:37&res=1
	応答	OSJ:37	-	-				
	要求	-	-	-				
	応答	-	-	-				
UPDATE PRESET THUMBNAIL	制御	OSJ:39:[Data1]	00	PRESET001	cam	OSJ:39:[Data]	-	http://192.168.0.10/cgi-bin/aw_cam?cmd=OSJ:39:00&res=1
	応答	OSJ:39:[Data]	-	-				
	要求	-	99	PRESET100				
	応答	-	-	-				
DELETE PRESET THUMBNAIL (SINGLE)	制御	OSJ:3A:[Data1]	00	PRESET001	cam	OSJ:3A:[Data]	-	http://192.168.0.10/cgi-bin/aw_cam?cmd=OSJ:3A:00&res=1
	応答	OSJ:3A:[Data]	-	-				
	要求	-	99	PRESET100				
	応答	-	-	-				
DELETE PRESET THUMBNAIL (ALL)	制御	OSJ:3B	-	-	cam	OSJ:3B	-	http://192.168.0.10/cgi-bin/aw_cam?cmd=OSJ:3B&res=1
	応答	OSJ:3B	-	-				
	要求	-	-	-				
	応答	-	-	-				

コマンド名	種別	コマンド	Data値	設定値	コマンドタイプ	更新通知	camdata.html	使用例・備考
PRESET NAME/PRESET THUMBNAIL COUNTER	制御	-	[Data1] 00h 01h 02h 03h	[Data1] PRESET 001-009 PRESET 010-018 PRESET 019-027 PRESET 028-036	cam	-	-	http://192.168.0.10/cgi-bin/aw_cam?cmd=QSJ:3C:00&res=1
	応答	-	04h 05h 06h 07h	PRESET 037-045 PRESET 046-054 PRESET 055-063 PRESET 064-072				
	要求	QSJ:3C:[Data1]	08h 09h 0Ah 0Bh	PRESET 073-081 PRESET 082-090 PRESET 091-099 PRESET 100				
	応答	OSJ:3C:[Data1]:[Data2]	[Data2] 00000000h - FFFFFFFFh	[Data2] 00000000H - FFFFFFFFH				

Preset再生時のシーケンスは6章参照

FILES

コマンド名	種別	コマンド	Data値	設定値	コマンドタイプ	更新通知	camdata.html	使用例・備考
SCENE FILE LOAD	制御	OSL:8F:[Data]	0	OFF	cam	OSL:8F:[Data]	OSL:8F:[Data]	http://192.168.0.10/cgi-bin/aw_cam?cmd=OSL:8F:1&res=1
	応答	OSL:8F:[Data]	1	SCENE1				
	要求	QSL:8F	-	-				
	応答	OSL:8F:[Data]	8	SCENE8				
SCENE FILE LOAD	制御	XSF:[Data]	0	-	cam	XSF:[Data]	XSF:[Data]	http://192.168.0.10/cgi-bin/aw_cam?cmd=XSF:1&res=1
	応答	XSF:[Data]	1	SCENE1				
	要求	QSF	0	SCENE1				
	応答	OSF:[Data]	8	SCENE8 OFF				
SCENE FILE STORE	制御	OSL:90:[Data]	1	SCENE1	cam	-	-	http://192.168.0.10/cgi-bin/aw_cam?cmd=OSL:90:1&res=1
	応答	OSL:90:[Data]	-	-				
	要求	-	8	SCENE8				
	応答	-	-	-				
SCENE FILE FILE NAME	制御	OSL:91:[Data1]:[Data2]	[Data1] 1	[Data1] SCENE1	cam	OSL:91:[Data1]:[Data2]	-	http://192.168.0.10/cgi-bin/aw_cam?cmd=OSL:91:5343454E453100000000000000000000&res=1 半角英数字 空白 ! # % & ' () * + , - . / : ; < = > ? [] _ ~
	応答	OSL:91:[Data1]:[Data2]	- 8	- SCENE8				
	要求	QSL:91:[Data1]	[Data2] xxxxxxx (30 DATA in ASCII CODE)	[Data2] SCENE FILE NAME (FIXED 15 CHARACTORS)				
	応答	OSL:91:[Data1]:[Data2]	-	-				
USER FILE LOAD	制御	OSL:92:[Data]	1	USER1	cam	OSL:92:[Data]	-	http://192.168.0.10/cgi-bin/aw_cam?cmd=OSL:92:1&res=1
	応答	OSL:92:[Data]	-	-				
	要求	-	3	USER3				
	応答	-	-	-				
USER FILE STORE	制御	OSL:93:[Data]	1	USER1	cam	-	-	http://192.168.0.10/cgi-bin/aw_cam?cmd=OSL:93:1&res=1
	応答	OSL:93:[Data]	-	-				
	要求	-	3	USER3				
	応答	-	-	-				
USER FILE FILE NAME	制御	OSL:94:[Data1]:[Data2]	[Data1] 1	[Data1] USER1	cam	OSL:94:[Data1]:[Data2]	-	http://192.168.0.10/cgi-bin/aw_cam?cmd=OSL:94:55534552310000000000000000000000&res=1 半角英数字 空白 ! # % & ' () * + , - . / : ; < = > ? [] _ ~
	応答	OSL:94:[Data1]:[Data2]	- 3	- USER3				
	要求	QSL:94:[Data1]	[Data2] xxxxxxx (30 DATA in ASCII CODE)	[Data2] SCENE FILE NAME (FIXED 15 CHARACTORS)				
	応答	OSL:94:[Data1]:[Data2]	-	-				

SCENEロード時にはSceneに属する各パラメータが変更され更新通知が送信されます

項目	コマンド	項目	コマンド
ND FILTER	OFT	B WHITE CLIP LEVEL	OSL:48
FLARE	OSA:11	HI-COLOR	OSL:49
GAMMA	OSA:0A	HI-COLOR LEVEL	OSL:4A
BLACK GAMMA	OSA:0B	EFFECT DEPTH	OSL:4B
KNEE	OSL:45	PRESET MATRIX	OSE:31
KNEE MODE	OSL:46, OSA:2D	LINEAR TABLE	OSA:00
WHITE CLIP	OSA:2E	COLOR CORRECT TABLE	OSL:6E
DRS	OSA:0D	MATRIX (R-G) N	OSD:2F
DETAIL	ODT	MATRIX (R-G) P	OSL:6F
SKIN TONE DETAIL	OSA:40	MATRIX (R-B) N	OSD:30
MATRIX	OSA:84	MATRIX (R-B) P	OSL:70

項目	コマンド	項目	コマンド
LINEAR MATRIX	OSL:6C	MATRIX (G-R) N	OSD:31
COLOR CORRECT	OSA:85	MATRIX (G-R) P	OSL:71
GAIN	OSL:25, OGU	MATRIX (G-B) N	OSD:32
AGC	OSL:26	MATRIX (G-B) P	OSL:72
AUTO IRIS	ORS:#D3	MATRIX (B-R) N	OSD:33
ATW	OSL:2A	MATRIX (B-R) P	OSL:73
WHITE BALANCE MODE	OSL:2B, OAW	MATRIX (B-G) N	OSD:34
SHUTTER SW	OSG:59	MATRIX (B-G) P	OSL:74
AUTO SHUTTER	OSL:2E	MEMORY SELECT	OSL:69
SHUTTER MODE	OSG:5A, OSJ:03	ZEBRA	OSA:49
G GAIN REL CONTROL SW	OSL:35	ZEBRA EFFECT MEMORY	OSL:6A
RGB GAIN PRESET > R GAIN	OSL:36	SKIN TONE EFFECT MEMORY	OSG:48
RGB GAIN PRESET > G GAIN	OSL:37	SKIN TONE CRISP	OSG:49
RGB GAIN PRESET > B GAIN	OSL:38	I CENTER	OSA:45
RGB GAIN ACH/BCH > R GAIN ACH	OSL:39	I WIDTH	OSA:46
RGB GAIN ACH/BCH > G GAIN ACH	OSL:3A	Q WIDTH	OSA:47
RGB GAIN ACH/BCH > B GAIN ACH	OSL:3B	Q PHASE	OSG:4F
RGB GAIN ACH/BCH > GAIN OFFSET ACH	OSJ:0C	G SAT	OSD:8E
RGB GAIN ACH/BCH > R GAIN BCH	OSL:3C	G CY SAT	OSD:90
RGB GAIN ACH/BCH > G GAIN BCH	OSL:3D	CY SAT	OSD:92
RGB GAIN ACH/BCH > B GAIN BCH	OSL:3E	CY_B SAT	OSD:94
RGB GAIN ACH/BCH > GAIN OFFSET BCH	OSL:3F	B SAT	OSD:96
AGC MAX GAIN	OSD:69	B_MG SAT	OSD:80
FRAME MIX SW	OSL:27	MG SAT	OSD:82
FRAME MIX	OSL:28, OSA:65	MG_R SAT	OSD:84
DAY/NIGHT	#D6	R SAT	OSD:86
MASTER PEDESTAL	OSJ:0F	R_YE SAT	OSD:88
R PEDESTAL	OSG:4C	YE SAT	OSD:8A
G PEDESTAL	OSG:4D	YE_G SAT	OSD:8C
B PEDESTAL	OSG:4E	G PHASE	OSD:8F
PEDESTAL OFFSET	OSJ:11	G_CY PHASE	OSD:91
MASTER FLARE	OSL:40	CY PHASE	OSD:93
R FLARE	OSL:41	CY_B PHASE	OSD:95
G FLARE	OSL:42	B PHASE	OSD:97
B FLARE	OSL:43	B_MG PHASE	OSD:81
MASTER DETAIL	OSA:30	MG PHASE	OSD:83
PEAK FREQUENCY	OSG:30	MG_R PHASE	OSD:85
CRISP	OSD:22	R PHASE	OSD:87
DETAIL GAIN(+)	OSA:38	R_YE PHASE	OSD:89
DETAIL GAIN(-)	OSA:39	YE PHASE	OSD:8B
DETAIL CLIP(+)	OSG:40	YE_G PHASE	OSD:8D
DETAIL CLIP(-)	OSG:41	DOWNCON > CHROMA LEVEL SW	OSL:4F
KNEE APERTURE LEVEL	OSG:3F	DOWNCON > CHROMA LEVEL	OSL:50
DETAIL KNEE	OSL:4C	DOWNCON > DETAIL	OSJ:14
LEVEL DEPENDENT SW	OSG:3E	DOWNCON > MASTER DETAIL	OSJ:15
LEVEL DEPENDENT	OSD:26	DOWNCON > H DETAIL LEVEL	OSL:51
DARK DETAIL SW	OSL:4D	DOWNCON > V DETAIL LEVEL	OSJ:17
DARK DETAIL	OSL:4E	DOWNCON > PEAK FREQUENCY	OSL:52
W. BAL VAR	OSI:20	DOWNCON > V DETAIL FREQUENCY	OSL:53
ATW SPEED	OSI:25	DOWNCON > CRISP	OSL:54
ATW TARGET R	OSJ:0D	DOWNCON > DETAIL CLIP(+)	OSL:57
ATW TARGET B	OSJ:0E	DOWNCON > DETAIL CLIP(-)	OSL:58
SHOCKLESS WB SW	OSL:2C	DOWNCON > KNEE APERTURE LEVEL	OSL:5A
SHOCKLESS WB SPEED	OSL:2D	DOWNCON > DETAIL KNEE	OSL:5B
AUTO SHUTTER LIMIT	OSD:BF	DOWNCON > LEVEL DEPENDENT SW	OSL:5C
SHUTTER SPEED	OSJ:06	DOWNCON > LEVEL DEPENDENT	OSL:5D
SYNCHRO SCAN	OSJ:09	DOWNCON > DARK DETAIL SW	OSL:5E
CHROMA LEVEL SW	OSG:93	DOWNCON > DARK DETAIL	OSL:5F
CHROMA LEVEL	OSL:BO, OSD:BO	DOWNCON > SKIN TONE DETAIL	OSL:60
COLOR TEMP ACH	OSJ:4A	DOWNCON > MEMORY SELECT	OSL:61
R GAIN ACH	OSJ:4B	DOWNCON > ZEBRA	OSL:61
B GAIN ACH	OSJ:4C	DOWNCON > ZEBRA EFFECT MEMORY	OSL:62

項目	コマンド	項目	コマンド
G AXIS ACH	OSJ:4D	DOWNCON > SKIN TONE EFFECT MEMORY	OSL:63
COLOR TEMP BCH	OSL:2F	DOWNCON > SKIN TONE CRISP	OSL:64
R GAIN BCH	OSL:32	DOWNCON > I CENTER	OSL:65
B GAIN BCH	OSL:33	DOWNCON > I WIDTH	OSL:66
G AXIS BCH	OSL:34	DOWNCON > Q WIDTH	OSL:67
GAMMA MODE SELECT	OSJ:D7	DOWNCON > Q PHASE	OSL:68
MASTER GAMMA	OSA:6A	DNR	OSD:3A
R GAMMA	OSI:35	DNR LEVEL	OSG:B5
B GAMMA	OSI:36	HDR PAINT > HLG MODE	OSI:39
MASTER BLACK GAMMA	OSA:07	HDR PAINT > SDR CONVERT MODE	OSI:3A
R BLACK GAMMA	OSA:08	HDR PAINT > BLACK GAMMA	OSI:3C
B BLACK GAMMA	OSA:09	HDR PAINT > MASTER BLACK GAMMA	OSI:3D
BLACK GAMMA RANGE	OSJ:1B	HDR PAINT > R BLACK GAMMA	OSI:3E
INITIAL GAMMA	OSL:44	HDR PAINT > B BLACK GAMMA	OSI:3F
KNEE MASTER POINT	OSA:20	HDR PAINT > KNEE	OSI:40
KNEE R POINT	OSA:22	HDR PAINT > KNEE POINT	OSI:41
KNEE B POINT	OSA:23	HDR PAINT > KNEE SLOPE	OSI:42
KNEE MASTER SLOPE	OSA:24	HDR PAINT > GAIN	OSI:43
KNEE R SLOPE	OSA:26	HDR PAINT > POINT	OSL:88
KNEE B SLOPE	OSA:27	HDR PAINT > SLOPE	OSL:89
AUTO KNEE RESPONSE	OSG:97	HDR PAINT > BLACK OFFSET	OSL:8A
MASTER WHITE CLIP LEVEL	OSA:2A	PICTURE LEVEL	OSD:48
R WHITE CLIP LEVEL	OSL:47	AUTO IRIS WINDOW POSISION	OSL:CD

USER FILEロード時にはSceneに属する各パラメータが変更され更新通知が送信されます

項目	コマンド	項目	コマンド
ND FILTER	OFT	DOWNCON > KNEE APERTURE LEVEL	OSL:5A
FLARE	OSA:11	DOWNCON > DETAIL KNEE	OSL:5B
GAMMA	OSA:0A	DOWNCON > LEVEL DEPENDENT SW	OSL:5C
BLACK GAMMA	OSA:0B	DOWNCON > LEVEL DEPENDENT	OSL:5D
KNEE	OSL:45	DOWNCON > DARK DETAIL SW	OSL:5E
KNEE MODE	OSL:46, OSA:2D	DOWNCON > DARK DETAIL	OSL:5F
WHITE CLIP	OSA:2E	DOWNCON > SKIN TONE DETAIL	OSL:60
DRS	OSA:0D	DOWNCON > MEMORY SELECT	OSL:B1
DETAIL	ODT	DOWNCON > ZEBRA	OSL:61
SKIN TONE DETAIL	OSA:40	DOWNCON > ZEBRA EFFECT MEMORY	OSL:62
MATRIX	OSA:84	DOWNCON > SKIN TONE EFFECT MEMORY	OSL:63
LINEAR MATRIX	OSL:6C	DOWNCON > SKIN TONE CRISP	OSL:64
COLOR CORRECT	OSA:85	DOWNCON > I CENTER	OSL:65
GAIN	OSL:25, OGU	DOWNCON > I WIDTH	OSL:66
AGC	OSL:26	DOWNCON > Q WIDTH	OSL:67
AUTO IRIS	ORS:#D3	DOWNCON > Q PHASE	OSL:68
ATW	OSL:2A	DNR	OSD:3A
WHITE BALANCE MODE	OSL:2B, OAW	DNR LEVEL	OSG:B5
SHUTTER SW	OSG:59	HDR PAINT > HLG MODE	OSI:39
AUTO SHUTTER	OSL:2E	HDR PAINT > SDR CONVERT MODE	OSI:3A
SHUTTER MODE	OSG:5A, OSJ:03	HDR PAINT > BLACK GAMMA	OSI:3C
G GAIN REL CONTROL SW	OSL:35	HDR PAINT > MASTER BLACK GAMMA	OSI:3D
RGB GAIN PRESET > R GAIN	OSL:36	HDR PAINT > R BLACK GAMMA	OSI:3E
RGB GAIN PRESET > G GAIN	OSL:37	HDR PAINT > B BLACK GAMMA	OSI:3F
RGB GAIN PRESET > B GAIN	OSL:38	HDR PAINT > KNEE	OSI:40
RGB GAIN ACH/BCH > R GAIN ACH	OSL:39	HDR PAINT > KNEE POINT	OSI:41
RGB GAIN ACH/BCH > G GAIN ACH	OSL:3A	HDR PAINT > KNEE SLOPE	OSI:42
RGB GAIN ACH/BCH > B GAIN ACH	OSL:3B	HDR PAINT > GAIN	OSI:43
RGB GAIN ACH/BCH > GAIN OFFSET ACH	OSJ:0C	HDR PAINT > POINT	OSL:88
RGB GAIN ACH/BCH > R GAIN BCH	OSL:3C	HDR PAINT > SLOPE	OSL:89
RGB GAIN ACH/BCH > G GAIN BCH	OSL:3D	HDR PAINT > BLACK OFFSET	OSL:8A
RGB GAIN ACH/BCH > B GAIN BCH	OSL:3E	PICTURE LEVEL	OSD:48
RGB GAIN ACH/BCH > GAIN OFFSET BCH	OSL:3F	WINDOW SELECT	OSJ:02
AGC MAX GAIN	OSD:69	PEAK RATIO	OSL:29
FRAME MIX SW	OSL:27	AUTO IRIS CLOSE LIMIT	OSJ:C0
FRAME MIX	OSL:28, OSA:65	IRIS SPEED	OSJ:01

項目	コマンド	項目	コマンド
DAY/NIGHT	#D6	V-LOG	OSJ:56
MASTER PEDESTAL	OSJ:0F	V-LOG PAINT SW	OSL:01
R PEDESTAL	OSG:4C	HDR	OSI:2C
G PEDESTAL	OSG:4D	GAMUT	OSL:02
B PEDESTAL	OSG:4E	SHOOTING MODE	OSI:30
PEDESTAL OFFSET	OSJ:11	BAUD RATE	OVP:04
MASTER FLARE	OSL:40	BAR	DCB
R FLARE	OSL:41	COLOR BAR TYPE	OSD:BA
G FLARE	OSL:42	ZONE	OSJ:27
B FLARE	OSL:43	TALLY	#TAE
MASTER DETAIL	OSA:30	TALLY BRIGHTNESS	OSA:D3
PEAK FREQUENCY	OSG:30	TALLY GUARD	OSL:04
CRISP	OSD:22	TALLY LED LIMIT R	OSJ:D9
DETAIL GAIN(+)	OSA:38	TALLY LED LIMIT G	OSJ:DA
DETAIL GAIN(-)	OSA:39	TALLY LED LIMIT Y	OSL:05
DETAIL CLIP(+)	OSG:40	EXTERNAL OUTPUT1	OSJ:41
DETAIL CLIP(-)	OSG:41	EXTERNAL OUTPUT2	OSJ:42
KNEE APERTURE LEVEL	OSG:3F	REF SIGNAL	OSL:08
DETAIL KNEE	OSL:4C	H PHASE-COARSE	OSL:09
LEVEL DEPENDENT SW	OSG:3E	H PHASE-FINE	OSL:0A
LEVEL DEPENDENT	OSD:26	BAR ID	OSD:BE
DARK DETAIL SW	OSL:4D	BAR ID > BRIGHTNESS	OSL:0B
DARK DETAIL	OSL:4E	BAR ID > ID1 POSITION V	OSL:0C
W. BAL VAR	OSI:20	BAR ID > ID1 POSITION H	OSL:0D
ATW SPEED	OSI:25	BAR ID > ID1	OSL:0E
ATW TARGET R	OSJ:0D	BAR ID > ID2 POSITION V	OSL:0F
ATW TARGET B	OSJ:0E	BAR ID > ID2 POSITION H	OSL:10
SHOCKLESS WB SW	OSL:2C	BAR ID > ID2	OSL:11
SHOCKLESS WB SPEED	OSL:2D	BAR ID > OFFSET V	OSL:12
AUTO SHUTTER LIMIT	OSD:BF	BAR ID > OFFSET H	OSL:13
SHUTTER SPEED	OSJ:06	12G SDI OUT/SFP+ HDR OUTPUT SELECT	OSJ:1F
SYNCHRO SCAN	OSJ:09	12G SDI OUT/SFP+V-LOG OUTPUT SELECT	OSJ:57
CHROMA LEVEL SW	OSG:93	12G SDI OUT/SFP+OUTPUT ITEM	OSL:14
CHROMA LEVEL	OSL:BO, OSD:BO	3G SDI OUT1 HDR OUTPUT SELECT	OSJ:22
COLOR TEMP ACH	OSJ:4A	3G SDI OUT1 V-LOG OUTPUT SELECT	OSJ:58
R GAIN ACH	OSJ:4B	3G SDI OUT1 OUTPUT ITEM	OSL:15
B GAIN ACH	OSJ:4C	CHAR	OSE:7B
G AXIS ACH	OSJ:4D	3G SDI OUT1 3G SDI	OSI:29
COLOR TEMP BCH	OSL:2F	3G SDI OUT2/PM OUTPUT SELECT	OSL:17
R GAIN BCH	OSL:32	3G SDI OUT2/PM HDR OUTPUT SELECT	OSJ:24
B GAIN BCH	OSL:33	3G SDI OUT2/PM V-LOG OUTPUT SELECT	OSJ:59
G AXIS BCH	OSL:34	3G SDI OUT2/PM OUTPUT ITEM	OSL:18
GAMMA MODE SELECT	OSJ:D7	3G SDI OUT2/PM 3G SDI	OSL:1A
MASTER GAMMA	OSA:6A	HDMI HDR OUTPUT SELECT	OSJ:26
R GAMMA	OSI:35	HDMI V-LOG OUTPUT SELECT	OSJ:5A
B GAMMA	OSI:36	VIDEO SAMPLING	OSE:68
MASTER BLACK GAMMA	OSA:07	RETURN1 ID	OSL:1B
R BLACK GAMMA	OSA:08	AUDIO	OSA:D0
B BLACK GAMMA	OSA:09	AUDIO > INPUT SELECT	OSL:1C
BLACK GAMMA RANGE	OSJ:1B	AUDIO > MIC GAIN	OSL:1D
INITIAL GAMMA	OSL:44	AUDIO > LINE LEVEL	OSA:D4
KNEE MASTER POINT	OSA:20	AUDIO > CH SELECT	OSL:1E
KNEE R POINT	OSA:22	AUDIO > CH1 VOLUME LEVEL	OSA:D5
KNEE B POINT	OSA:23	AUDIO > CH2 VOLUME LEVEL	OSA:D5
KNEE MASTER SLOPE	OSA:24	AUDIO > HEAD ROOM	OSA:D6
KNEE R SLOPE	OSA:26	IP(H.264/H.265) OUTPUT ITEM	OSL:23
KNEE B SLOPE	OSA:27	FOCUS MODE	OAF: #D1
AUTO KNEE RESPONSE	OSG:97	AF SENSITIVITY	OSJ:D8
MASTER WHITE CLIP LEVEL	OSA:2A	ZOOM MODE	OSE:70, OSD:B3
R WHITE CLIP LEVEL	OSL:47	MAX DIGITAL ZOOM	OSE:7A
B WHITE CLIP LEVEL	OSL:48	DIGITAL EXTENDER	OSJ:4E
HI-COLOR	OSL:49	O. I. S.	OSL:8B

項目	コマンド	項目	コマンド
HI-COLOR LEVEL	OSL:4A	O. I. S. MODE	OSL:8C, OIS
EFFECT DEPTH	OSL:4B	WFM MODE	OSL:8D
PRESET MATRIX	OSE:31	WFM POSITION	OSL:8E
LINEAR TABLE	OSA:00	RETURN SELECT	OSL:B3
COLOR CORRECT TABLE	OSL:6E	STATUS (AUTO)	OSA:88
MATRIX (R-G) N	OSD:2F	LEVEL GAUGE	OSL:03
MATRIX (R-G) P	OSL:6F	SERIAL	OSJ:54
MATRIX (R-B) N	OSD:30	IP	OSJ:55
MATRIX (R-B) P	OSL:70	INVERT PAN/TILT AXIS	OSJ:C1
MATRIX (G-R) N	OSD:31	CAMERA ID	OSJ:F4
MATRIX (G-R) P	OSL:71	UHD CROP	OSJ:2E
MATRIX (G-B) N	OSD:32	CROP ZOOM	OSJ:92
MATRIX (G-B) P	OSL:72	CROP AF	OSJ:91
MATRIX (B-R) N	OSD:33	3G SDI1 OUT	OSI:32
MATRIX (B-R) P	OSL:73	NDI OUT	OSJ:93
MATRIX (B-G) N	OSD:34	IP (H. 264/H. 265) OUT1	OSI:33
MATRIX (B-G) P	OSL:74	IP (H. 264/H. 265) OUT2	OSJ:94
MEMORY SELECT	OSL:69	CROP MARKER	OSI:1A
ZEBRA	OSA:49	CROP OUT	OSI:16
ZEBRA EFFECT MEMORY	OSL:6A	CROP ADJUST	OSI:17
SKIN TONE EFFECT MEMORY	OSG:48	CROP H POSITION	OSJ:AF, OSJ:2F, OSJ:31, OSJ:33
SKIN TONE CRISP	OSG:49	CROP V POSITION	OSJ:80, OSJ:30, OSJ:32, OSJ:34
I CENTER	OSA:45	CROP ZOOM RATIO	OSJ:B1, OSJ:98, OSJ:99, OSJ:9A
I WIDTH	OSA:46	SMART PICTURE FLIP	#SPF
Q WIDTH	OSA:47	INSTALL POSITION	#INS
Q PHASE	OSG:4F	FLIP DETECT ANGLE	#FDA
G SAT	OSD:8E	P/T SPEED MODE	OSJ:2D
G CY SAT	OSD:90	P/T ACCELERATION	OSJ:A2
CY SAT	OSD:92	P/T ACCELERATION > RISE S-CURVE	OSJ:A3
CY B SAT	OSD:94	P/T ACCELERATION > FALL S-CURVE	OSJ:A4
B SAT	OSD:96	P/T ACCELERATION > RISE ACCELERATION	OSJ:A5
B MG SAT	OSD:80	P/T ACCELERATION > FALL ACCELERATION	OSJ:A6
MG SAT	OSD:82	SPEED WITH ZOOM POSITION	#SWZ
MG R SAT	OSD:84	FOCUS ADJUST WITH PTZ.	OAZ
R SAT	OSD:86	PRIVACY MODE	OSJ:A7
R YE SAT	OSD:88	POWER ON POSITION	OSJ:45
YE SAT	OSD:8A	PRESET NUMBER	OSJ:46
YE G SAT	OSD:8C	PRESET SPEED UNIT	OSJ:29
G PHASE	OSD:8F	PRESET SPEED	#UPVS
G CY PHASE	OSD:91	PRESET SPEED TABLE	#PST
CY PHASE	OSD:93	PRESET ACCELERATION	OSJ:A8
CY B PHASE	OSD:95	PRESET ACCELERATION > RISE S-CURVE	OSJ:A9
B PHASE	OSD:97	PRESET ACCELERATION > FALL S-CURVE	OSJ:AA
B MG PHASE	OSD:81	PRESET ACCELERATION > RISE ACCELERATION	OSJ:AB
MG PHASE	OSD:83	PRESET ACCELERATION > FALL ACCELERATION	OSJ:AC
MG R PHASE	OSD:85	PRESET ACCELERATION > RISE RAMP	OSJ:AD
R PHASE	OSD:87	PRESET ACCELERATION > FALL RAMP	OSJ:AE
R YE PHASE	OSD:89	PRESET SCOPE	OSE:71
YE PHASE	OSD:8B	PRESET DIGITAL EXTENDER	OSE:7C
YE G PHASE	OSD:8D	PRESET CROP	OSJ:2A
DOWNCON > CHROMA LEVEL SW	OSL:4F	PRESET THUMBNAIL UPDATE	OSJ:2B
DOWNCON > CHROMA LEVEL	OSL:50	PRESET NAME	OSJ:2C
DOWNCON > DETAIL	OSJ:14	PRESET IRIS	OSJ:5B
DOWNCON > MASTER DETAIL	OSJ:15	PRESET SHUTTER	OSJ:D5
DOWNCON > H DETAIL LEVEL	OSL:51	PRESET ZOOM MODE	OSE:7D
DOWNCON > V DETAIL LEVEL	OSJ:17	FREEZE DURING PRESET	#PRF
DOWNCON > PEAK FREQUENCY	OSL:52	FAN1	#FAN
DOWNCON > V DETAIL FREQUENCY	OSL:53	FAN2	#FA2
DOWNCON > CRISP	OSL:54	WIRELESS CONTROL	#WLC

項目	コマンド	項目	コマンド
DOWNCON > DETAIL CLIP(+)	OSL:57	WIRELESS ID	#RID
DOWNCON > DETAIL CLIP(-)	OSL:58	STATUS LAMP	#LMP
AUTO IRIS WINDOW POSISION	OSL:CD	PRESET PTZ SYNC MODE	OSL:CE

MAINTENANCE

コマンド名	種別	コマンド	Data値	設定値	コマンドタイプ	更新通知	camdata.html	使用例・備考
FAN1	制御	#FAN[Data]	0	AUTO	ptz	fAN[Data]	fAN[Data]	http://192.168.0.10/cgi-bin/aw_ptz?cmd=%23FAN0&res=1
	応答	fAN[Data]	1	HIGH				
	要求	#FAN	2	MID				
	応答	fAN[Data]	3	LOW				
FAN STATUS1	制御	-	0	OFF	ptz	fS1[Data]	-	http://192.168.0.10/cgi-bin/aw_ptz?cmd=%23FS1&res=1
	応答	-	1	ON				
	要求	#FS1	2	ERROR				
	応答	fS1[Data]						
FAN2	制御	#FA2[Data]	0	AUTO	ptz	fA2[Data]	fA2[Data]	http://192.168.0.10/cgi-bin/aw_ptz?cmd=%23FA20&res=1
	応答	fA2[Data]	1	HIGH				
	要求	#FA2	2	MID				
	応答	fA2[Data]	3	LOW				
FAN STATUS2	制御	-	0	OFF	ptz	fS2[Data]	-	http://192.168.0.10/cgi-bin/aw_ptz?cmd=%23FS2&res=1
	応答	-	1	ON				
	要求	#FS2	2	ERROR				
	応答	fS2[Data]						
SYSTEM VERSION	制御	-	VXX.XX-XXX-XX.XX	VXX.XX-XXX-XX.XX Ex) V01.00-000-00.00	cam	-	-	http://192.168.0.10/cgi-bin/aw_cam?cmd=QSL:99&res=1
	応答	-						
	要求	QSL:99						
	応答	OSL:99:[Data]						
SYSTEM VERSION	制御	-	-	VXX.XX Ex) V01.00	cam	-	-	http://192.168.0.10/cgi-bin/aw_cam?cmd=QSV&res=1
	応答	-						
	要求	QSV						
	応答	OSV:[Data1]						
ERROR STATUS	制御	-	0	Normal	cam	OER:[Data]	OER:[Data]	http://192.168.0.10/cgi-bin/aw_cam?cmd=QER&res=1
	応答	-	1	Fan Error				
	要求	QER	2	Other Error				
	応答	OER:[Data]						
ERROR STATUS	制御	-	00000000h 00000001h 00000002h 00000004h 00000008h 00000010h	No Error Fan Error High Temperature Lens Error Pan/Tilt Error Sensor Error	cam	OSI:46:[Data]	OSI:46:0x[Data]	http://192.168.0.10/cgi-bin/aw_cam?cmd=QSI:46&res=1
	応答	-						
	要求	QSI:46						
	応答	OSI:46:[Data]						

コマンド名	種別	コマンド	Data値	設定値	コマンドタイプ	更新通知	camdata.html	使用例・備考
ERROR INFORMATION	制御	-	00h 03h 21h 22h 25h 30h	No Error Motor Driver Error System Error Spec Limit Over BE Life-monitoring Error NET Life-monitoring Error	ptz	rER[Data]	-	http://192.168.0.10/cgi-bin/aw_ptz?cmd=%23RER&res=1
	応答	-	31h 32h 33h 36h 40h 41h 42h 43h	Fan1 error Fan2 error High Temp Low Temp Temp Sensor Error Lens Initialize Error PT. Initialize Error PoE++ Software auth.				
	要求	#RER	50h 52h 55h 57h	Timeout MR Level Error MR Offset Error PT. Gear Error				
	応答	rER[Data]	58h 60h 61h 62h 63h	Gyro Error PT. Initialize Error Update Firmware Error Update Hardware Error Update Error Update Fan Error				
WHITE SHADING CORRECT	制御	OSL:9B:[Data]	0 1	OFF ON	cam	OSL:9B:[Data]	-	http://192.168.0.10/cgi-bin/aw_cam?cmd=OSL:9B:1&res=1
	応答	OSL:9B:[Data]						
	要求	QSL:9B						
	応答	OSL:9B:[Data]						
WHITE SHADING W H SAW R	制御	OSL:9C:[Data]	1Ch	-100	cam	OSL:9C:[Data]	-	http://192.168.0.10/cgi-bin/aw_cam?cmd=OSL:9C:81&res=1
	応答	OSL:9C:[Data]	-	-				
	要求	QSL:9C	80h	0				
	応答	OSL:9C:[Data]	E4h	+100				
WHITE SHADING W H SAW G	制御	OSL:9D:[Data]	1Ch	-100	cam	OSL:9D:[Data]	-	http://192.168.0.10/cgi-bin/aw_cam?cmd=OSL:9D:81&res=1
	応答	OSL:9D:[Data]	-	-				
	要求	QSL:9D	80h	0				
	応答	OSL:9D:[Data]	E4h	+100				
WHITE SHADING W H SAW B	制御	OSL:9E:[Data]	1Ch	-100	cam	OSL:9E:[Data]	-	http://192.168.0.10/cgi-bin/aw_cam?cmd=OSL:9E:81&res=1
	応答	OSL:9E:[Data]	-	-				
	要求	QSL:9E	80h	0				
	応答	OSL:9E:[Data]	E4h	+100				
WHITE SHADING W H PARA R	制御	OSL:9F:[Data]	1Ch	-100	cam	OSL:9F:[Data]	-	http://192.168.0.10/cgi-bin/aw_cam?cmd=OSL:9F:81&res=1
	応答	OSL:9F:[Data]	-	-				
	要求	QSL:9F	80h	0				
	応答	OSL:9F:[Data]	E4h	+100				
WHITE SHADING W H PARA G	制御	OSL:A0:[Data]	1Ch	-100	cam	OSL:A0:[Data]	-	http://192.168.0.10/cgi-bin/aw_cam?cmd=OSL:A0:81&res=1
	応答	OSL:A0:[Data]	-	-				
	要求	QSL:A0	80h	0				
	応答	OSL:A0:[Data]	E4h	+100				
WHITE SHADING W H PARA B	制御	OSL:A1:[Data]	1Ch	-100	cam	OSL:A1:[Data]	-	http://192.168.0.10/cgi-bin/aw_cam?cmd=OSL:A1:81&res=1
	応答	OSL:A1:[Data]	-	-				
	要求	QSL:A1	80h	0				
	応答	OSL:A1:[Data]	E4h	+100				

コマンド名	種別	コマンド	Data値	設定値	コマンドタイプ	更新通知	camdata.html	使用例・備考		
WHITE SHADING W V SAW R	制御	OSL:A2:[Data]	1Ch	-100	cam	OSL:A2:[Data]	-	http://192.168.0.10/cgi-bin/aw_cam?cmd=OSL:A2:81&res=1		
	応答	OSL:A2:[Data]	-	-						
	要求	QSL:A2	80h	0						
	応答	OSL:A2:[Data]	E4h	+100						
WHITE SHADING W V SAW G	制御	OSL:A3:[Data]	1Ch	-100	cam	OSL:A3:[Data]	-	http://192.168.0.10/cgi-bin/aw_cam?cmd=OSL:A3:81&res=1		
	応答	OSL:A3:[Data]	-	-						
	要求	QSL:A3	80h	0						
	応答	OSL:A3:[Data]	E4h	+100						
WHITE SHADING W V SAW B	制御	OSL:A4:[Data]	1Ch	-100	cam	OSL:A4:[Data]	-	http://192.168.0.10/cgi-bin/aw_cam?cmd=OSL:A4:81&res=1		
	応答	OSL:A4:[Data]	-	-						
	要求	QSL:A4	80h	0						
	応答	OSL:A4:[Data]	E4h	+100						
WHITE SHADING W V PARA R	制御	OSL:A5:[Data]	1Ch	-100	cam	OSL:A5:[Data]	-	http://192.168.0.10/cgi-bin/aw_cam?cmd=OSL:A5:81&res=1		
	応答	OSL:A5:[Data]	-	-						
	要求	QSL:A5	80h	0						
	応答	OSL:A5:[Data]	E4h	+100						
WHITE SHADING W V PARA G	制御	OSL:A6:[Data]	1Ch	-100	cam	OSL:A6:[Data]	-	http://192.168.0.10/cgi-bin/aw_cam?cmd=OSL:A6:81&res=1		
	応答	OSL:A6:[Data]	-	-						
	要求	QSL:A6	80h	0						
	応答	OSL:A6:[Data]	E4h	+100						
WHITE SHADING W V PARA B	制御	OSL:A7:[Data]	1Ch	-100	cam	OSL:A7:[Data]	-	http://192.168.0.10/cgi-bin/aw_cam?cmd=OSL:A7:81&res=1		
	応答	OSL:A7:[Data]	-	-						
	要求	QSL:A7	80h	0						
	応答	OSL:A7:[Data]	E4h	+100						
WIRELESS CONTROL	制御	#WLC[Data1]	0	DISABLE	ptz	wLC[Data1]	-	http://192.168.0.10/cgi-bin/aw_ptz?cmd=%23WLC1&res=1		
	応答	wLC[Data1]								
	要求	#WLC							1	ENABLE
	応答	wLC[Data1]								
WIRELESS ID	制御	#RID[Data]	0	CAM1	ptz	rID[Data]	-	http://192.168.0.10/cgi-bin/aw_ptz?cmd=%23RID0&res=1		
	応答	rID[Data]							1	CAM2
	要求	#RID							2	CAM3
	応答	rID[Data]							3	CAM4
STATUS LAMP	制御	#LMP[Data]	0	DISABLE	ptz	IMP[Data]	-	http://192.168.0.10/cgi-bin/aw_ptz?cmd=%23LMP0&res=1		
	応答	IMP[Data]								
	要求	#LMP							1	ENABLE
	応答	IMP[Data]								

OSD

コマンド名	種別	コマンド	Data値	設定値	コマンドタイプ	更新通知	camdata.html	使用例・備考
MENU ON/OFF	制御	DUS:[Data]	0 1	OFF ON	cam	-	OUS:[Data]	http://192.168.0.10/cgi-bin/aw_cam?cmd=DUS:1&res=1
	応答	DUS:[Data]						
	要求	QUS						
	応答	OUS:[Data]						
MENU CANCEL	制御	DPG:[Data]	1	CANCEL	cam	-	-	http://192.168.0.10/cgi-bin/aw_cam?cmd=DPG:1&res=1
	応答	DPG:[Data]						
	要求	-						
	応答	-						
MENU ENTER	制御	DIT:[Data]	1	ENTER	cam	-	-	http://192.168.0.10/cgi-bin/aw_cam?cmd=DIT:1&res=1
	応答	DIT:[Data]						
	要求	-						
	応答	-						
MENU UP (DIAL)	制御	DUP:[Data]	1	UP	cam	-	-	http://192.168.0.10/cgi-bin/aw_cam?cmd=DUP:1&res=1
	応答	DUP:[Data]						
	要求	-						
	応答	-						
MENU DOWN (DIAL)	制御	DDW:[Data]	1	DOWN	cam	-	-	http://192.168.0.10/cgi-bin/aw_cam?cmd=DDW:1&res=1
	応答	DDW:[Data]						
	要求	-						
	応答	-						
MENU UP	制御	CUP:[Data]	1	UP	cam	-	-	http://192.168.0.10/cgi-bin/aw_cam?cmd=CUP:1&res=1
	応答	CUP:[Data]						
	要求	-						
	応答	-						
MENU DOWN	制御	CDW:[Data]	1	DOWN	cam	-	-	http://192.168.0.10/cgi-bin/aw_cam?cmd=CDW:1&res=1
	応答	CDW:[Data]						
	要求	-						
	応答	-						
MENU RIGHT	制御	CRT:[Data]	1	RIGHT	cam	-	-	http://192.168.0.10/cgi-bin/aw_cam?cmd=CRT:1&res=1
	応答	CRT:[Data]						
	要求	-						
	応答	-						
MENU LEFT	制御	CLT:[Data]	1	LEFT	cam	-	-	http://192.168.0.10/cgi-bin/aw_cam?cmd=CLT:1&res=1
	応答	CLT:[Data]						
	要求	-						
	応答	-						

OTHERS

コマンド名	種別	コマンド	Data値	設定値	コマンドタイプ	更新通知	camdata.html	使用例・備考
MODEL NUMBER	制御	-		AW-UE160	cam	-	OID:AW-UE100	http://192.168.0.10/cgi-bin/aw_cam?cmd=QID&res=1
	応答	-						
	要求	QID						
	応答	OID:[Data]						
CAMERA NUMBER	制御	OSL:AE:[Data]	01	1	cam	OSL:AE:[Data]	OSL:AE:[Data]	http://192.168.0.10/cgi-bin/aw_cam?cmd=OSL:AE:01&res=1
	応答	OSL:AE:[Data]	-	-				
	要求	OSL:AE	99	99				
	応答	OSL:AE:[Data]						
POWER ON / STANDBY	制御	#0[Data]	0	STANDBY	ptz	p[Data]	p[Data]	http://192.168.0.10/cgi-bin/aw_ptz?cmd=%2300&res=1
	応答	p[Data]	1	POWERON				
	要求	#0	0	STANDBY				
	応答	p[Data]	3	POWERON STARTING				
RESOLUTION CONTROL	制御	#RZL[Data]	0	640X360	ptz	rZL[Data]	-	http://192.168.0.10/cgi-bin/aw_ptz?cmd=%23RZL0&res=1
	応答	rZL[Data]	1	320X180				
	要求	#RZL	2	1280X720				
	応答	rZL[Data]	3	1920X1080				
CAMERA TITLE	制御	OSJ:5C:[Data]	xxxxxxx (40 DATA in ASCII CODE)	CAMERA TITLE (FIXED 20 CHARACTORS)	cam	OSJ:5C:[Data]	OSJ:5C:[Data]	http://192.168.0.10/cgi-bin/aw_cam?cmd=OSJ:5C:41572D55453136300000000000000000000000&res=1
	応答	OSJ:5C:[Data]						
	要求	OSJ:5C						
	応答	OSJ:5C:[Data]						