

TAWERS WGIII

APPLICATION TYPE

Hot wire allows high-deposition and high-speed welding!

TAWERS-TIG

WGIII

TS	TM	TL
800	1100	1800
950	1400	

- TS: External
- TM: External
- TL: External

High-frequency start!



TAWERS-TIG Start Unit

An excellent arc start
Allows to improve welding
quality and reduce
cycle time.



Aluminium is not applicable

Closer electrode-to-filler distance improves pre-heating of the filler.

Example of high-speed welding (80 cm/min, Stainless steel)

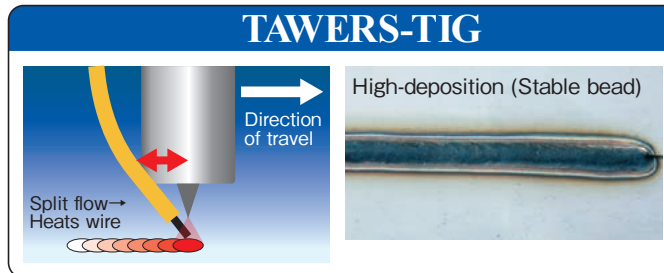

Curved neck filler conduit!

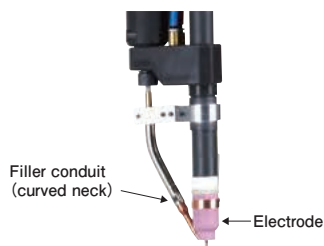

Stable filler wire feeding
Allows to improve welding quality and limit deviation of aiming point.

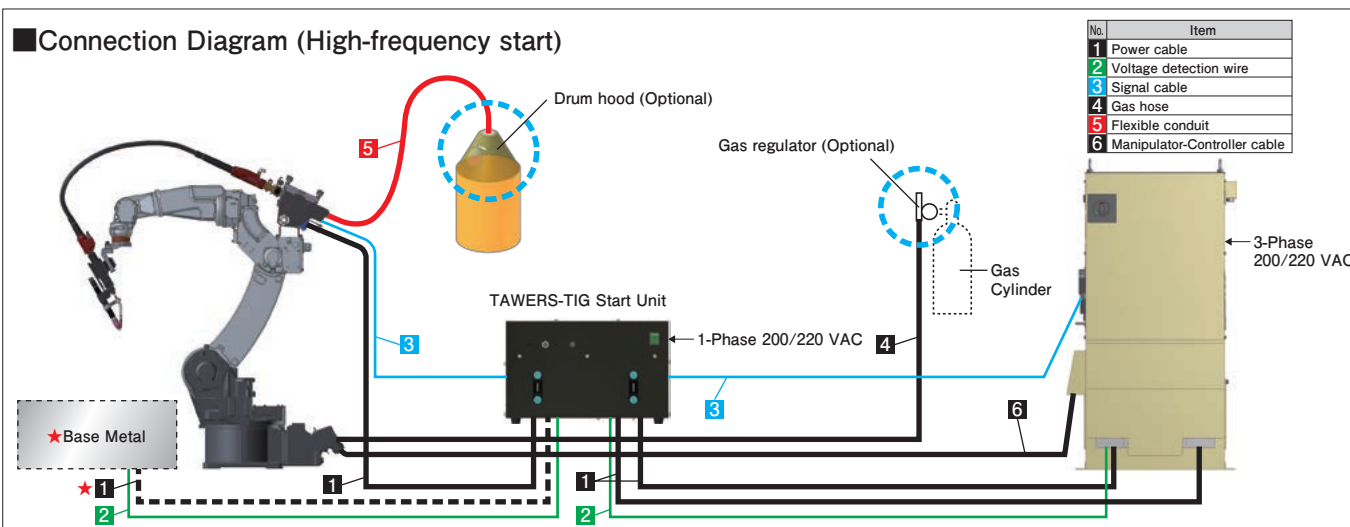

★ Customer supplied items

Consult us for details.